



Precision Ball Screw/Spline

Rotary-Nut Series

Linear Motion + Rotary Motion

BNS/NS

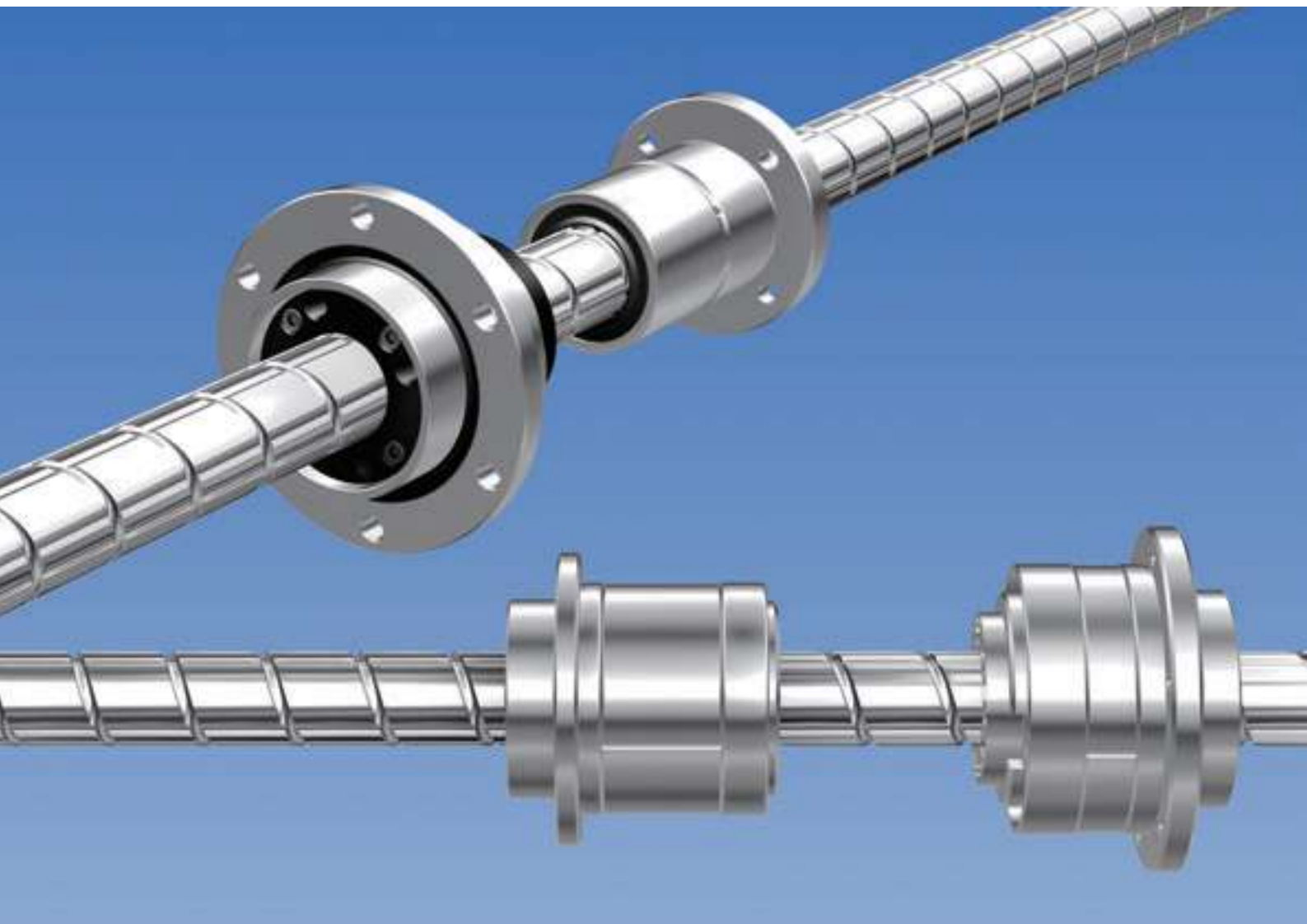

Contents

▼ Precision Ball Screw/Spline Models BNS/NS

Structure and Features	P.2
Types	P.3
Static Safety Factor	P.4
Rated Life and Service Life Time ...	P.5
Accuracy	P.6
Action Patterns	P.7
Examples of Installation	P.10
Example of Use	P.10
Dimensional Tables Model BNS-A ...	P.11 to12
Model BNS.....	P.13to14
Model NS-A ...	P.15to16
Model NS ...	P.17to18



Rotary-Nut Series Precision Ball Screw/Spline

BNS/NS

[Japanese patent No.] 2060726 (model NS), 2060727 (model BNS)

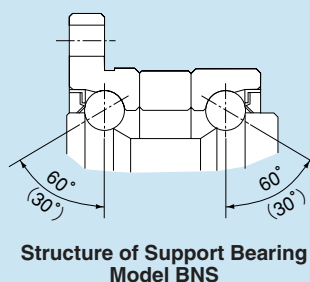
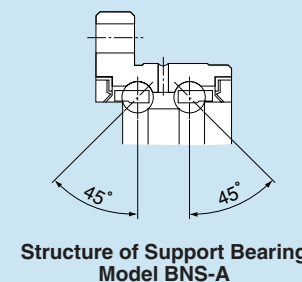
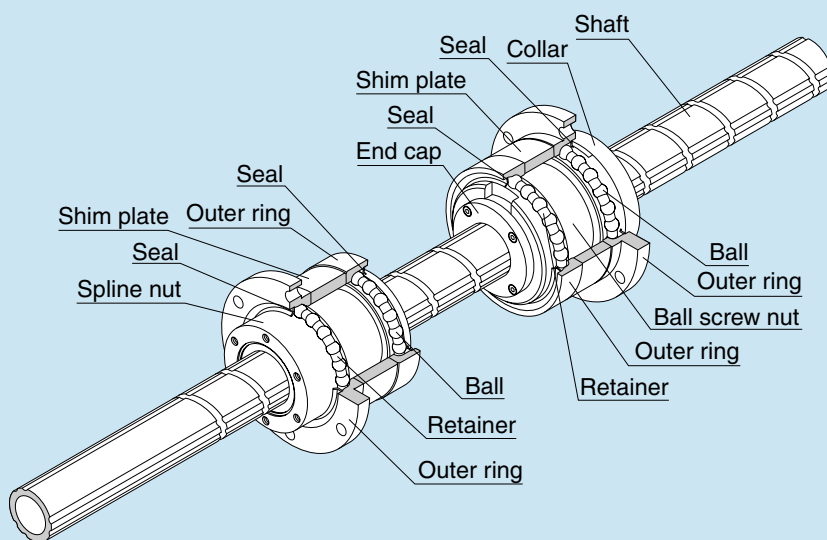

Structure of Precision Ball Screw/Spline

Structure and Features

The Ball Screw/Spline is a linear-rotary unit that contains Ball Screw grooves and Ball Spline grooves crossing with each other on a single shaft. The nuts of the Ball Screw and the Ball Spline have dedicated support bearings directly embedded on the circumference of the nuts.

The Ball Screw/Spline is capable of performing three (rotary, linear and spiral) modes of motion with a single shaft by rotating or stopping the ball screw nut or the spline nut.

It is optimal for machines using a combination of rotary and linear motions, such as a SCARA robot's Z-axis, assembly robot, automatic loader, and machining center's ATC equipment.

● Zero Axial Clearance

The Ball Spline has an angular-contact structure that causes no backlash in the rotational direction, enabling highly accurate positioning.

● Lightweight and Compact

Since the ball screw nut is integrated with the support bearing, highly accurate and compact design is allowed. In addition, small inertia through the lightweight ball screw nut ensures high responsiveness.

● Smooth Motion with Low Noise

As the Ball Screw is based on an end-cap mechanism, smooth motion with low noise is achieved.

● Highly Rigid Support Bearing

The support bearing on the Ball Screw has a contact angle of 60° in the axial direction while that on the Ball Spline has a contact angle of 30° in the moment direction, thus provide a highly rigid shaft support.

In addition, a dedicated rubber seal is attached as standard to prevent entry of foreign material.

● Easy Installation

The ball spline nut is designed so that balls do not fall off even if the spline nut is removed from the shaft, thus making installation easy. The Ball Screw/Spline can easily be mounted simply by securing it to the housing with bolts (for the housing's inner-diameter tolerance, H7 is recommended).

Types

Model BNS-A [compact type: linear motion + rotary motion]

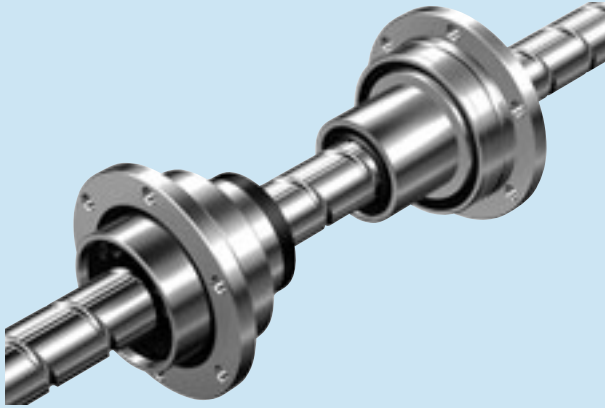

Model BNS [heavy-load type: linear motion + rotary motion]

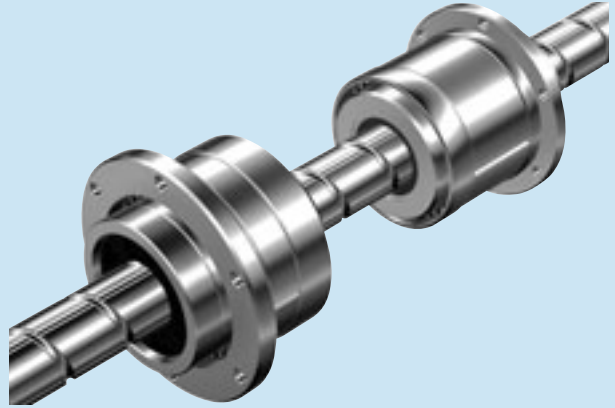

Model NS-A [compact type: linear motion]

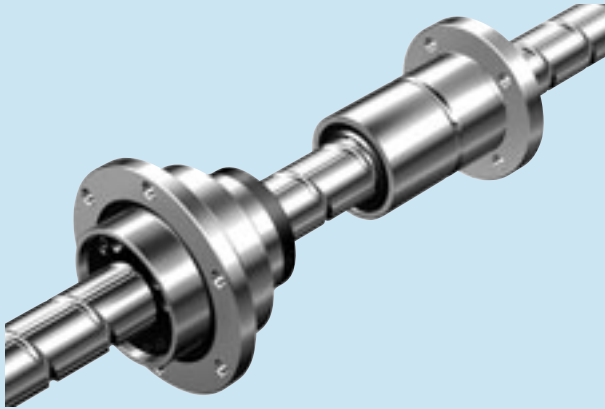

Model NS [heavy-load type: linear motion]

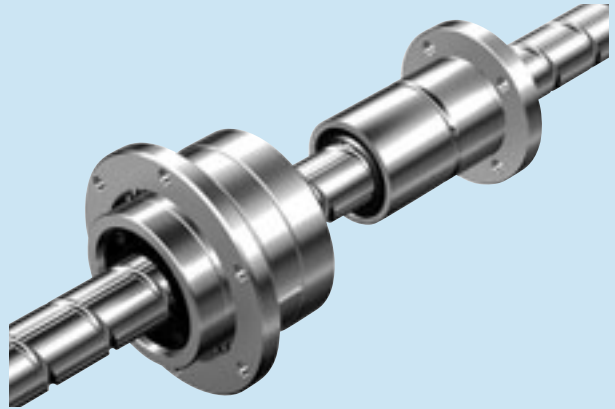

Static Safety Factor

It is necessary to take into account a static safety factor indicated in Table 1 against the axial load that is applied on the Ball Screw. When studying the static safety factor, a basic static load rating C_{0a} is required.

Ball Screw Unit

[Basic Static Load Rating C_{0a}]

When a Ball Screw receives an excessive load or a large impact load while it is stationary or in motion, a local permanent deformation occurs between the raceway and the steel ball. If the permanent deformation exceeds a certain limit, it will prevent the Ball Screw from smoothly moving.

It is recognized that in general there will be no operational problem if the amount of permanent deformation is up to approximately 0.0001 of the steel ball diameter. The load present in such cases is called basic static load rating C_{0a} .

[Static Safety Factor]

$$f_s \geq \frac{C_{0a}}{F_a}$$

f_s : Static safety factor (see Table 1)

C_{0a} : Basic static load rating (kN) (see the corresponding dimensional table)

F_a : Axial load (kN)

Table 1 Static Safety Factor

Machine using the Ball Screw	Load conditions	Lower limit of f_s
General industrial machinery	Without vibrations or impact	1.0 to 1.3
	With vibrations or impact	2.0 to 3.0
Machine tools	Without vibrations or impact	1.0 to 1.5
	With vibrations or impact	2.5 to 7.0

Ball Spline Unit

[Basic Static Load Rating C_0]

When a Ball Spline receives an excessive load or a large impact load while it is stationary or in motion, a local permanent deformation occurs between the raceway and the rolling element. If the permanent deformation exceeds a certain limit, it will prevent the Ball Spline from smoothly moving.

The basic static load rating is a static load with a constant direction and magnitude whereby the sum of the permanent deformation of the rolling element and that of the raceway on the contact area under the maximum stress is 0.0001 times the rolling element diameter. With the Ball Spline, it is defined in terms of radial load. Therefore, the basic static load rating is considered to be the limit of the static permissible load rating.

[Static Safety Factor f_s]

When the Ball Spline is stationary or in motion, an unexpected external force may be applied through inertia caused by vibrations, impact or start/stop. It is necessary to take into account a static safety factor against such a working load.

A static safety factor (f_s) of a Ball Spline is expressed in how many times greater is the load capacity (basic static load rating C_0) than the load applied on the Ball Spline.

$$f_s = \frac{C_0}{P}$$

f_s : Static safety factor

C_0 : Basic static load rating (N)

P : Calculated load (N)

Rated Life and Service Life Time

Ball Screw Unit

[Basic Dynamic Load Rating Ca]

Basic dynamic load rating Ca is used to calculate the service life of a Ball Screw in motion with its ball screw nut being under a load. The basic dynamic load rating Ca is an axial load under which the rated life of 90% of a group of the same Ball Screw units independently operating is 10⁶ rev (1 million revolutions).

[Rated Life]

The service life of a Ball Screw is obtained from the equation below using the basic dynamic load rating and the axial load.

$$L = \left(\frac{C_a}{f_w \cdot F_a} \right)^3 \times 10^6$$

- L : Rated life (rev)
- C_a : Basic dynamic load rating (N) (see the corresponding dimensional table)
- F_a : Axial load (N)
- f_w : Load factor (see Table 2)

Table 2 Load Factor

Vibrations/impact	Velocity (V)	f _w
Faint	Very low V ≤ 0.25 m/s	1.0 to 1.2
Weak	Low 0.25 ≤ V ≤ 1.0 m/s	1.2 to 1.5
Medium	Moderate 1.0 ≤ V ≤ 2.0 m/s	1.5 to 2.0
Strong	High 2.0 m/s < V	2.0 to 3.5

[Service Life Time]

When the rated life (L) has been determined, the service life time is obtained from the following equation if the stroke length and the number of reciprocations are constant.

$$L_h = \frac{L \times \ell}{2 \times \ell_s \times n_1 \times 60}$$

- L_h : Service life time (h)
- ℓ : Stroke length (mm)
- n₁ : Revolutions per minute (min⁻¹)
- ℓ : Lead (mm)

(For details, see the General Catalog.)

Ball Spline Unit

[Rated Life When a Torque is Applied]

$$L = \left(\frac{f_r \cdot f_c}{f_w} \cdot \frac{C_T}{T_c} \right)^3 \times 50$$

[Rated Life When a Radial Load is Applied]

$$L = \left(\frac{f_r \cdot f_c}{f_w} \cdot \frac{C}{P_c} \right)^3 \times 50$$

- L : Rated life (km)
- C_T : Basic dynamic torque rating (N·m)
- T_c : Calculated load torque (N·m)
- C : Basic dynamic load rating (N)
- P_c : Calculated radial load (N)
- f_r : Temperature factor (see the General Catalog)
- f_c : Contact factor (see the General Catalog)
- f_w : Load factor (see the General Catalog)

[Service Life Time]

When the rated life (L) has been determined, the service life time is obtained if the stroke length and the number of oscillations are constant.

$$L_h = \frac{L \times 10^3}{2 \times \ell_s \times n_1 \times 60}$$

- L_h : Service life time (h)
- ℓ_s : Stroke length (m)
- n₁ : Oscillations per minute (opm)

(For details, see the General Catalog.)

Accuracy

The Ball Screw/Spline is manufactured with the following specifications.

Ball Screw Unit

Axial clearance : 0 or below

Lead accuracy : C5

(For details of the specification values, see the General Catalog.)

Ball Spline Unit

Clearance in the rotational direction : 0 or below (CL: light preload)

Accuracy : class H

(For details of the specification values, see the General Catalog.)

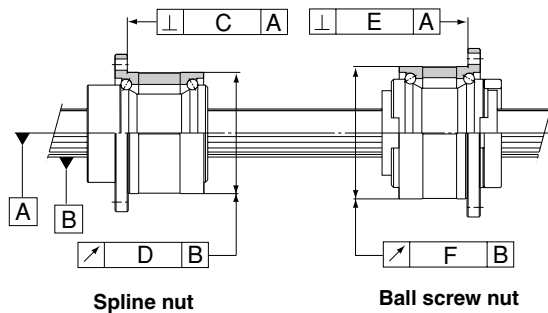

Model BNS

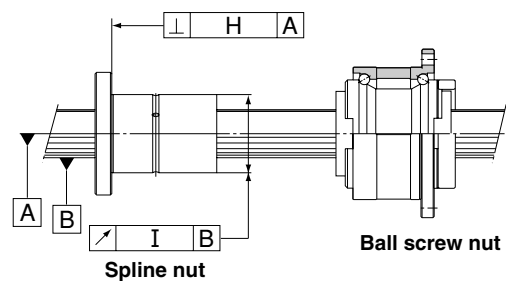

Model NS

Unit: mm

Model No.	C	D	E	F	H	I
BNS 0812	0.014	0.017	0.014	0.016	0.010	0.013
NS 0812	0.014	0.017	0.014	0.016	0.010	0.013
BNS 1015	0.014	0.017	0.014	0.016	0.010	0.013
NS 1015	0.014	0.017	0.014	0.016	0.010	0.013
BNS 1616	0.018	0.021	0.016	0.020	0.013	0.016
NS 1616	0.018	0.021	0.016	0.020	0.013	0.016
BNS 2020	0.018	0.021	0.016	0.020	0.013	0.016
NS 2020	0.018	0.021	0.016	0.020	0.013	0.016
BNS 2525	0.021	0.021	0.018	0.024	0.016	0.016
NS 2525	0.021	0.021	0.018	0.024	0.016	0.016
BNS 3232	0.021	0.021	0.018	0.024	0.016	0.016
NS 3232	0.021	0.021	0.018	0.024	0.016	0.016
BNS 4040	0.025	0.025	0.021	0.033	0.019	0.019
NS 4040	0.025	0.025	0.021	0.033	0.019	0.019
BNS 5050	0.025	0.025	0.021	0.033	0.019	0.019
NS 5050	0.025	0.025	0.021	0.033	0.019	0.019

Action Patterns

Basic Actions of Model BNS

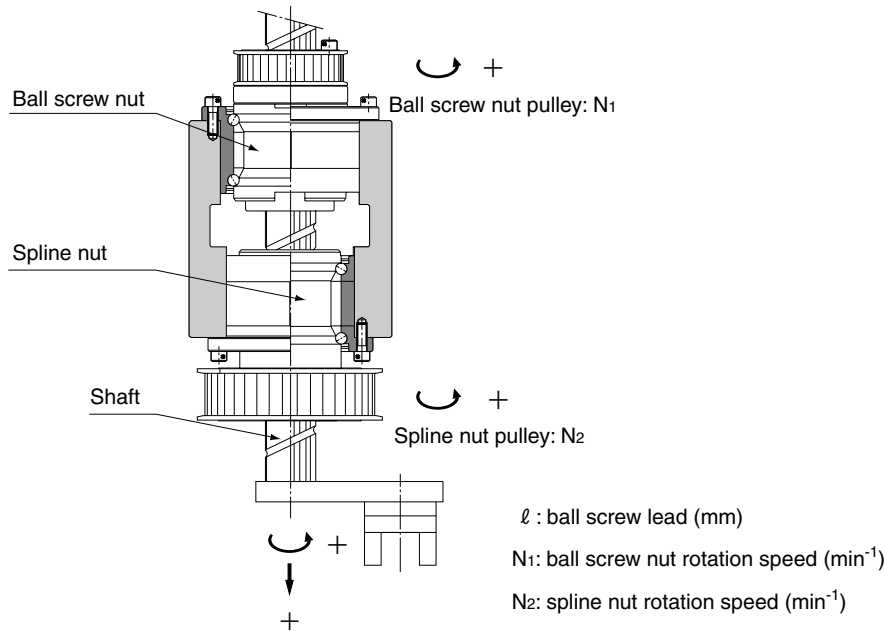

Motion	Action direction	Input		Shaft motion	
		Ball Screw pulley	Ball Spline pulley	Vertical direction (speed)	Rotational direction (rotation speed)
1. Vertical 	① Vertical direction → downward Rotational direction → 0	N_1	0	$V=N_1 \cdot l$	0
		(Forward)		$(N_1 \neq 0)$	
	② Vertical direction → upward Rotational direction → 0	$-N_1$	0	$V=-N_1 \cdot l$	0
		(Reverse)		$(N_1 \neq 0)$	
2. Rotational 	① Vertical direction → 0 Rotational direction → forward	N_1	N_2	0	N_2 (Forward)
			(Forward)		$(N_1=N_2 \neq 0)$
	② Vertical direction → 0 Rotational direction → reverse	$-N_1$	$-N_2$	0	$-N_2$ (Reverse)
			(Reverse)		$(-N_1=-N_2 \neq 0)$
3. Spiral 	① Vertical direction → upward Rotational direction → forward	0	N_2	$V=N_2 \cdot l$	N_2
			$(N_2 \neq 0)$		(Forward)
	② Vertical direction → downward Rotational direction → reverse	0	$-N_2$	$V=-N_2 \cdot l$	$-N_2$
			$(-N_2 \neq 0)$		(Reverse)

Basic Actions of Model NS

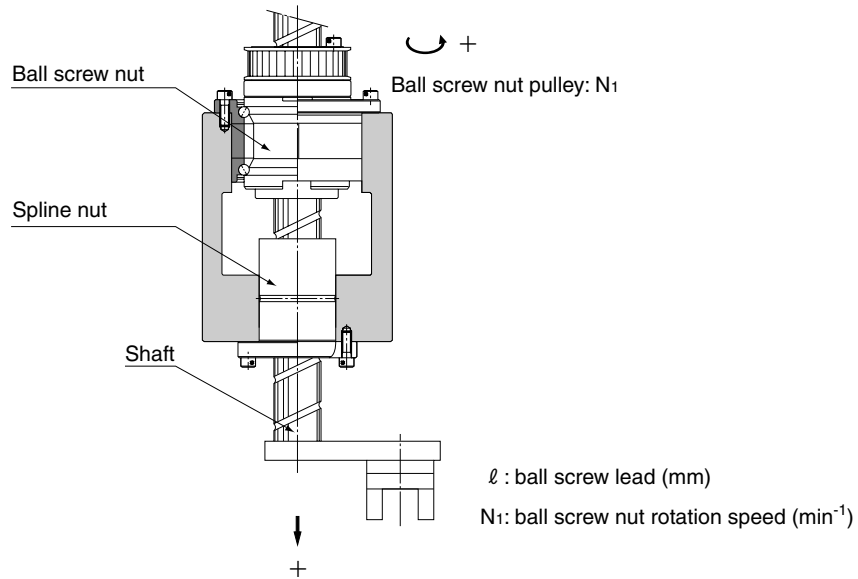

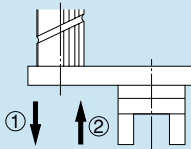
Motion	Action direction	Input	Shaft motion
		Ball Screw pulley	Vertical direction (speed)
1. Vertical 	① Vertical direction → downward	N ₁ (Forward)	V=N ₁ · ℓ (N ₁ ≠0)
	② Vertical direction → upward	-N ₁ (Reverse)	V=-N ₁ · ℓ (N ₁ ≠0)

Extended Actions of Model BNS

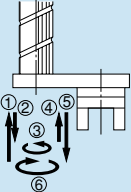
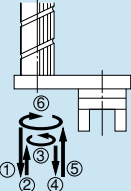
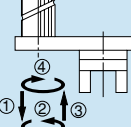
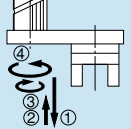
Motion	Action direction	Input		Shaft motion		
		Ball Screw pulley	Ball Spline pulley	Vertical direction (speed)	Rotational direction (rotation speed)	
1. Upward → downward → forward → upward → downward → reverse 	①	Vertical direction → upward	$-N_1$ (Reverse)	0	$V = -N_1 \cdot \ell$ ($N_1 \neq 0$)	0
	②	Vertical direction → downward	N_1 (Forward)	0	$V = N_1 \cdot \ell$ ($N_1 \neq 0$)	0
	③	Rotational direction → forward	N_1	N_2 (Forward)	0	N_2 (Forward) ($N_1 = N_2 \neq 0$)
	④	Vertical direction → upward	$-N_1$	0	$V = -N_1 \cdot \ell$ ($N_1 \neq 0$)	0
	⑤	Vertical direction → downward	N_1	0	$V = N_1 \cdot \ell$ ($N_1 \neq 0$)	0
	⑥	Rotational direction → reverse	$-N_1$	$-N_2$ (Reverse)	0	$-N_2$ (Reverse) ($-N_1 = N_2 \neq 0$)
2. Downward → upward → forward → downward → upward → reverse 	①	Vertical direction → downward	N_1	0	$V = N_1 \cdot \ell$ ($N_1 \neq 0$)	0
	②	Vertical direction → upward	$-N_1$	0	$V = -N_1 \cdot \ell$ ($N_1 \neq 0$)	0
	③	Rotational direction → forward	N_1	N_2	0	N_2 ($N_1 = N_2 \neq 0$)
	④	Vertical direction → downward	N_1	0	$V = N_1 \cdot \ell$ ($N_1 \neq 0$)	0
	⑤	Vertical direction → upward	$-N_1$	0	$V = -N_1 \cdot \ell$ ($N_1 \neq 0$)	0
	⑥	Rotational direction → reverse	$-N_1$	$-N_2$	0	$-N_2$ ($-N_1 = N_2 \neq 0$)
3. Downward → forward → upward → reverse 	①	Vertical direction → downward	N_1	0	$V = N_1 \cdot \ell$ ($N_1 \neq 0$)	0
	②	Rotational direction → forward	N_1	N_2	0	N_2 ($N_1 = N_2 \neq 0$)
	③	Vertical direction → upward	$-N_1$	0	$V = -N_1 \cdot \ell$ ($N_1 \neq 0$)	0
	④	Rotational direction → reverse	$-N_1$	$-N_2$	0	$-N_2$ ($-N_1 = N_2 \neq 0$)
4. Downward → upward → forward → reverse 	①	Vertical direction → downward	N_1	0	$V = N_1 \cdot \ell$ ($N_1 \neq 0$)	0
	②	Vertical direction → upward	$-N_1$	0	$V = -N_1 \cdot \ell$ ($N_1 \neq 0$)	0
	③	Rotational direction → reverse	$-N_1$	$-N_2$	0	$-N_2$ ($-N_1 = N_2 \neq 0$)
	④	Rotational direction → forward	N_1	N_2	0	N_2 ($N_1 = N_2 \neq 0$)

Examples of Installation

[Example of Installing Model BNS]

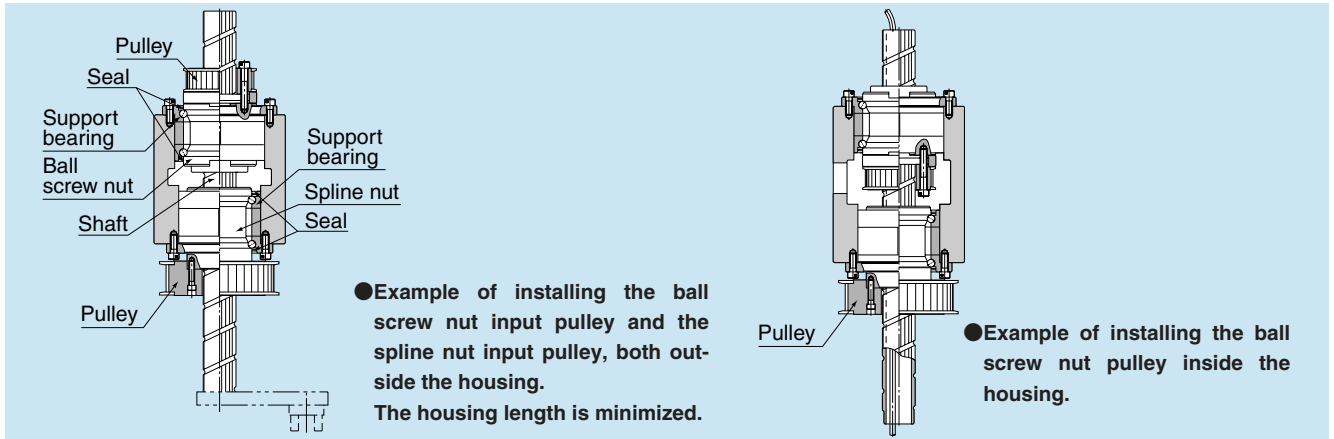

[Example of Installing Model NS]

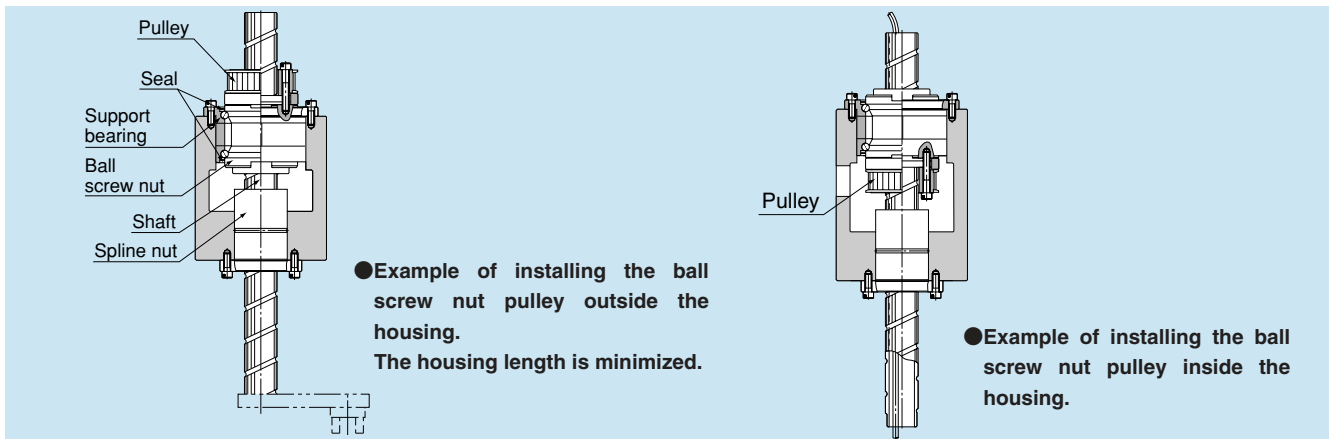

Example of Use

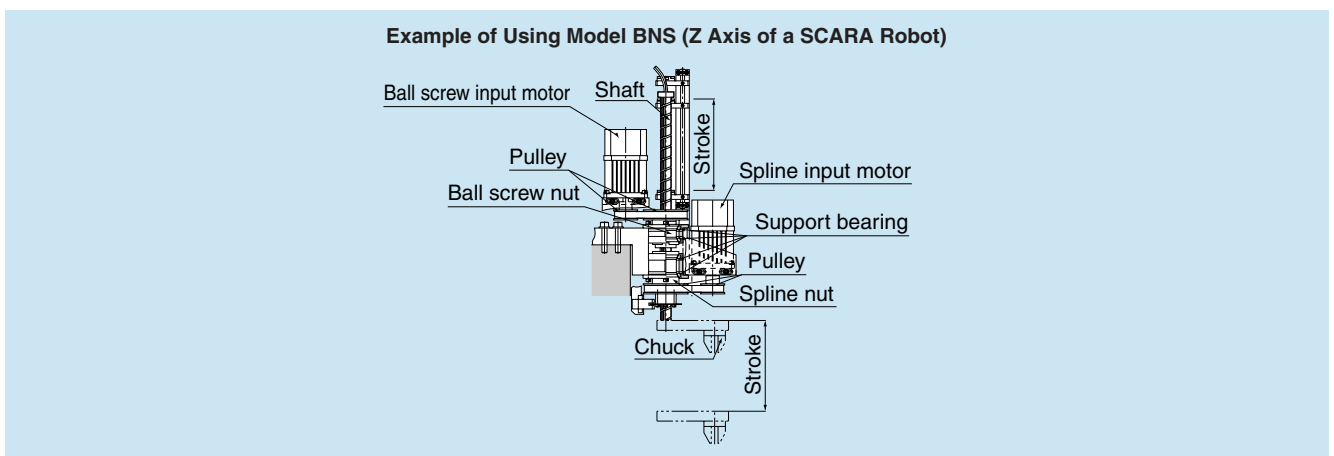

Model BNS-A

Dimensional Table for Model BNS-A

Compact Type: Linear Motion + Rotary Motion

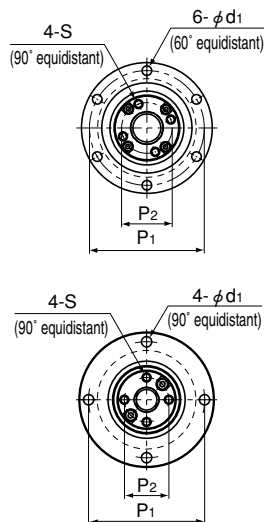

Models BNS 0812A and 1015A

Ball screw unit

Model No.	Screw shaft outer diameter d	Screw shaft inner diameter dp	Lead Ph	Ball screw dimensions									
				Basic load rating		Ball center-to-center diameter dp	Thread minor diameter dc	Outer diameter D g6	Flange diameter D ₁	Overall length L ₁	D ₃ h7	D ₄ H7	BE
				Ca kN	C _{0a} kN								
BNS 0812A	8	—	12	1.1	1.8	8.4	6.6	32	44	28.5	22	19	19
BNS 1015A	10	—	15	1.7	2.7	10.5	8.3	36	48	34.5	26	23	23
BNS 1616A	16	11	16	3.9	7.2	16.65	13.7	48	64	40	36	32	32
BNS 2020A	20	14	20	6.1	12.3	20.75	17.5	56	72	48	43.5	39	39
BNS 2525A	25	18	25	9.1	19.3	26	22	66	86	58	52	47	47
BNS 3232A	32	23	32	13	29.8	33.25	28.3	78	103	72	63	58	58
BNS 4040A	40	29	40	21.4	49.7	41.75	35.2	100	130	88	79.5	73	73

Ball spline

Model No.	Ball spline dimensions									
	Basic load rating		Static permissible moment M _A N-m	Basic torque rating		Outer diameter D ₇ g6	Flange diameter D ₅	Overall length L ₂	D ₆ h7	BE ₁
	C kN	C ₀ kN		C _T N-m	C _{0T} N-m					
BNS 0812A	1.5	2.6	5.9	2	2.9	32	44	25	24	16
BNS 1015A	2.7	4.9	15.7	3.9	7.8	36	48	33	28	21
BNS 1616A	7.1	12.6	67.6	31.4	34.3	48	64	50	36	31
BNS 2020A	10.2	17.8	118	56.8	55.8	56	72	63	43.5	35
BNS 2525A	15.2	25.8	210	105	103	66	86	71	52	42
BNS 3232A	20.5	34	290	180	157	78	103	80	63	52
BNS 4040A	37.8	60.5	687	418	377	100	130	100	79.5	64

Note For the db dimension (shaft diameter 16 to 40), solid shaft and K hollow shaft (thick) is available. For details, see the "Ball Spline" page of the General Catalog.

Example of model number coding

BNS2020A +500L

Model number Overall shaft length (in mm)

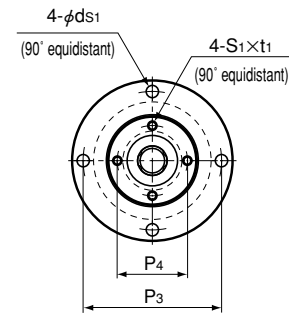
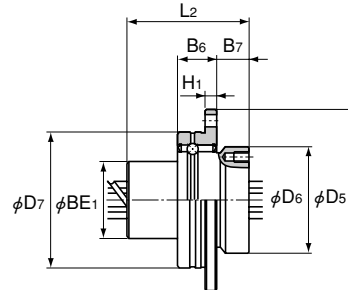
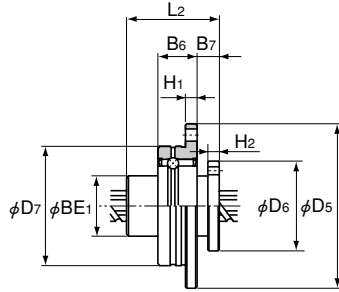
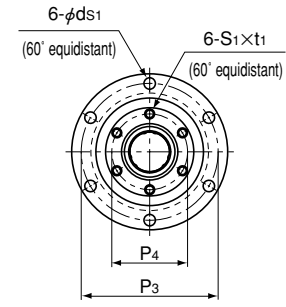
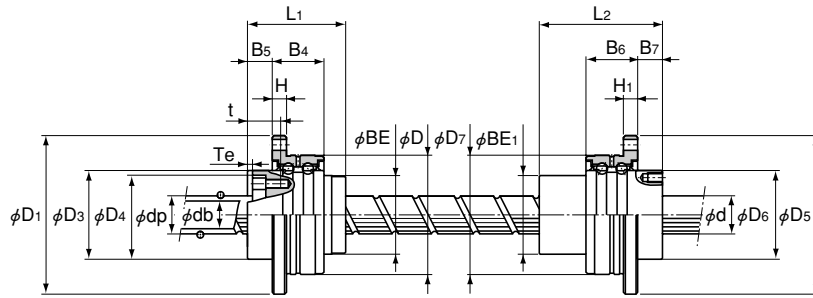

Model BNS 0812A

Model BNS 1015A

Models BNS 0812A and 1015A

Unit: mm

	H	B ₄	B ₅	T _e	P ₁	P ₂	S	t	d ₁	Support bearing basic load rating		Nut inertial moment kg · cm ²	Screw shaft inertial moment/mm J kg · cm ² /mm	Nut mass kg	Shaft mass kg/m
										C _a kN	C _{0a} kN				
	3	10.5	7	1.5	38	14.5	M2.6	10	3.4	0.8	0.5	0.03	3.16×10 ⁻⁵	0.08	0.35
	3	10.5	8	1.5	42	18	M3	11.5	3.4	0.9	0.7	0.08	7.71×10 ⁻⁵	0.15	0.52
	6	21	10	2	56	25	M4	13.5	4.5	8.7	10.5	0.35	3.92×10 ⁻⁴	0.31	0.8
	6	21	11	2.5	64	31	M5	16.5	4.5	9.7	13.4	0.85	9.37×10 ⁻⁴	0.54	1.21
	7	25	13	3	75	38	M6	20	5.5	12.7	18.2	2.12	2.2×10 ⁻³	0.88	1.79
	8	25	14	3	89	48	M6	21	6.6	13.6	22.3	5.42	5.92×10 ⁻³	1.39	2.96
	10	33	16.5	3	113	61	M8	24.5	9	21.5	36.8	17.2	1.43×10 ⁻²	3.16	4.51

Unit: mm

	H ₁	B ₆	B ₇	H ₂	P ₃	P ₄	S ₁ ×t ₁	d _{s1}	Support bearing basic load rating		Nut inertial moment kg · cm ²	Nut mass kg
									C kN	C ₀ kN		
	3	10.5	6	3	38	19	M2.6×3	3.4	0.6	0.2	0.03	0.08
	3	10.5	9	—	42	23	M3×4	3.4	0.8	0.3	0.08	0.13
	6	21	10	—	56	30	M4×6	4.5	6.7	6.4	0.44	0.35
	6	21	12	—	64	36	M5×8	4.5	7.4	7.8	0.99	0.51
	7	25	13	—	75	44	M5×8	5.5	9.7	10.6	2.2	0.79
	8	25	17	—	89	54	M6×10	6.6	10.5	12.5	5.17	1.25
	10	33	20	—	113	68	M6×10	9	16.5	20.7	16.1	2.51

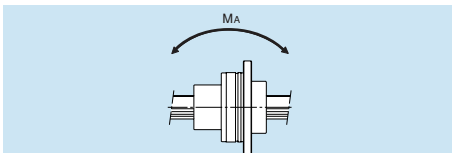

Model BNS

Dimensional Table for Model BNS

Heavy-load Type: Linear Motion + Rotary Motion

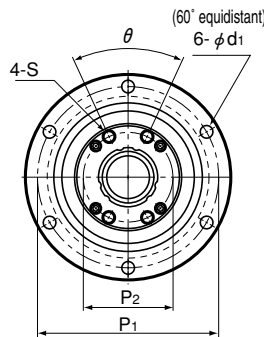

Ball screw unit

Model No.	Screw shaft outer diameter d	Screw shaft inner diameter dp	Lead Ph	Ball screw dimensions									
				Basic load rating		Ball center-to-center diameter dp	Thread minor diameter dc	Outer diameter D	Flange diameter D ₁	Overall length L ₁	D ₃ h7	D ₄ H7	
				Ca kN	C _{0a} kN								
BNS 1616	16	11	16	3.9	7.2	16.65	13.7	52	$0_{-0.007}$	68	43.5	40	32
BNS 2020	20	14	20	6.1	12.3	20.75	17.5	62	$0_{-0.007}$	78	54	50	39
BNS 2525	25	18	25	9.1	19.3	26	22	72	$0_{-0.007}$	92	65	58	47
BNS 3232	32	23	32	13	29.8	33.25	28.3	80	$0_{-0.007}$	105	80	66	58
BNS 4040	40	29	40	21.4	49.7	41.75	35.2	110	$0_{-0.008}$	140	98	90	73
BNS 5050	50	36	50	31.8	77.6	52.2	44.1	120	$0_{-0.008}$	156	126	100	90

Ball spline

Model No.	Ball spline dimensions								
	Basic load rating		Static permissible moment M _A N-m	Basic torque rating		Outer diameter D ₇	Flange diameter D ₅	Overall length L ₂	
	C kN	C ₀ kN		C _T N-m	C _{0T} N-m				
BNS 1616	7.1	12.6	67.6	31.4	34.3	52	$0_{-0.007}$	68	50
BNS 2020	10.2	17.8	118	56.8	55.8	56	$0_{-0.007}$	72	63
BNS 2525	15.2	25.8	210	105	103	62	$0_{-0.007}$	78	71
BNS 3232	20.5	34	290	180	157	80	$0_{-0.007}$	105	80
BNS 4040	37.8	60.5	687	418	377	100	$0_{-0.008}$	130	100
BNS 5050	60.9	94.5	1340	842	768	120	$0_{-0.008}$	156	125

Note Dimension "U" indicates the length from the head of the hexagon socket bolt to the ball screw nut end face.

Note For the db dimension, solid shaft and K hollow shaft (thick) are available. For details, see the "Ball Spline" page of the General Catalog.

Example of model number coding

BNS2525 +600L

Model number Overall shaft length (in mm)

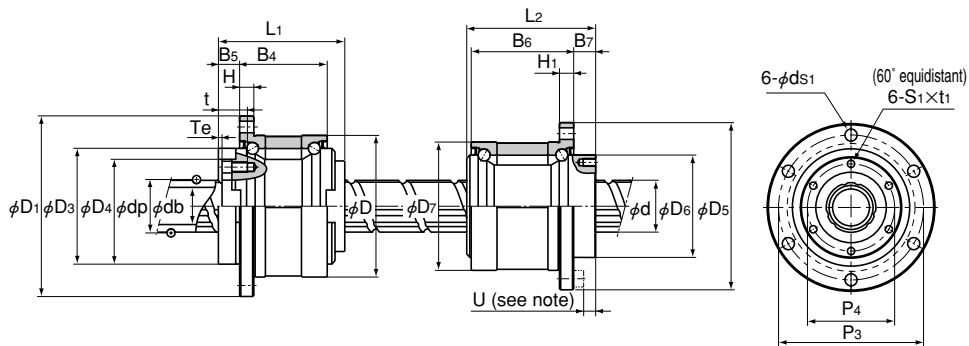

Unit: mm

	H	B ₄	B ₅	T _e	P ₁	P ₂	S	t	d _i	θ°	Support bearing basic load rating		Nut inertial moment kg · cm ²	Screw shaft inertial moment/mm J kg · cm ² /mm	Nut mass kg	Shaft mass kg/m
											C _a kN	C _{0a} kN				
	5	27.5	9	2	60	25	M4	12	4.5	40	19.4	19.2	0.48	3.92×10 ⁻⁴	0.38	0.8
	6	34	11	2	70	31	M5	16	4.5	40	26.8	29.3	1.44	9.37×10 ⁻⁴	0.68	1.21
	8	43	12.5	3	81	38	M6	19	5.5	40	28.2	33.3	3.23	2.2×10 ⁻³	1.1	1.79
	9	55	14	3	91	48	M6	19	6.6	40	30	39	6.74	5.92×10 ⁻³	1.74	2.96
	11	68	16.5	3	123	61	M8	22	9	50	59.3	74.1	27.9	1.43×10 ⁻²	3.95	4.51
	12	80	25	4	136	75	M10	28	11	50	62.2	83	58.2	3.52×10 ⁻²	6.22	7.16

Unit: mm

	D ₆ h7	H ₁	B ₆	B ₇	P ₃	P ₄	S ₁ ×t ₁	d _{s1}	U	Support bearing basic load rating		Nut inertial moment kg · cm ²	Nut mass kg
										C kN	C ₀ kN		
	39.5	5	37	10	60	32	M5×8	4.5	5	12.7	11.8	0.52	0.51
	43.5	6	48	12	64	36	M5×8	4.5	7	16.2	15.5	0.87	0.7
	53	6	55	13	70	45	M6×8	4.5	8	17.6	18	1.72	0.93
	65.5	9	60	17	91	55	M6×10	6.6	10	20.1	24	5.61	1.8
	79.5	11	74	23	113	68	M6×10	9	13	37.2	42.5	14.7	3.9
	99.5	12	97	25	136	85	M10×15	11	13	41.6	54.1	62.5	6.7

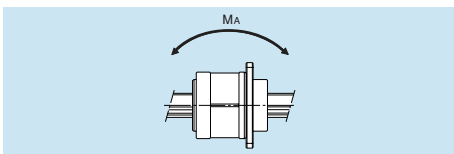

Model NS-A

Dimensional Table for Model NS-A Compact Type: Linear Motion

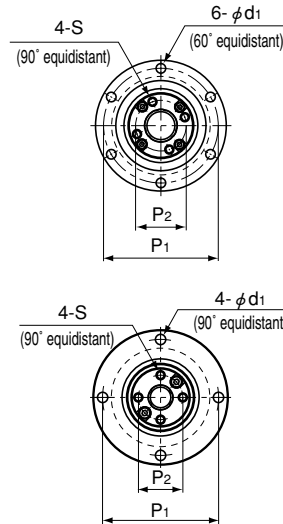

Models BNS 0812A and 1015A

Ball screw unit

Model No.	Screw shaft outer diameter d	Screw shaft inner diameter dp	Lead Ph	Ball screw dimensions									
				Basic load rating		Ball center-to-center diameter dp	Thread minor diameter dc	Outer diameter D g6	Flange diameter D ₁	Overall length L ₁	D ₃ h7	D ₄ H7	BE
				Ca kN	C _{0a} kN								
NS 0812A	8	—	12	1.1	1.8	8.4	6.6	32	44	28.5	22	19	19
NS 1015A	10	—	15	1.7	2.7	10.5	8.3	36	48	34.5	26	23	23
NS 1616A	16	11	16	3.9	7.2	16.65	13.7	48	64	40	36	32	32
NS 2020A	20	14	20	6.1	12.3	20.75	17.5	56	72	48	43.5	39	39
NS 2525A	25	18	25	9.1	19.3	26	22	66	86	58	52	47	47
NS 3232A	32	23	32	13	29.8	33.25	28.3	78	103	72	63	58	58
NS 4040A	40	29	40	21.4	49.7	41.75	35.2	100	130	88	79.5	73	73

Ball spline

Model No.	Ball spline dimensions						
	Basic load rating		Static permissible moment M _A N-m	Basic torque rating		Outer diameter D ₇	Flange diameter D _{5-0.2} ⁰
	C kN	C ₀ kN		C _T N-m	C _{0T} N-m		
NS 0812A	1.5	2.6	5.9	2	2.9	16 ⁰ _{-0.011}	32
NS 1015A	2.8	4.9	15.7	3.9	7.8	21 ⁰ _{-0.013}	42
NS 1616A	7.1	12.6	67.6	31.4	34.3	31 ⁰ _{-0.013}	51
NS 2020A	10.2	17.8	118	56.8	55.8	35 ⁰ _{-0.016}	58
NS 2525A	15.2	25.8	210	105	103	42 ⁰ _{-0.016}	65
NS 3232A	20.5	34	290	180	157	49 ⁰ _{-0.016}	77
NS 4040A	37.8	60.5	687	418	377	64 ⁰ _{-0.019}	100

Note For the db dimension (shaft diameter 16 to 40), solid shaft and K hollow shaft (thick) is available. For details, see the "Ball Spline" page of the General Catalog.

Example of model number coding

NS2020A +500L

Model number Overall shaft length (in mm)

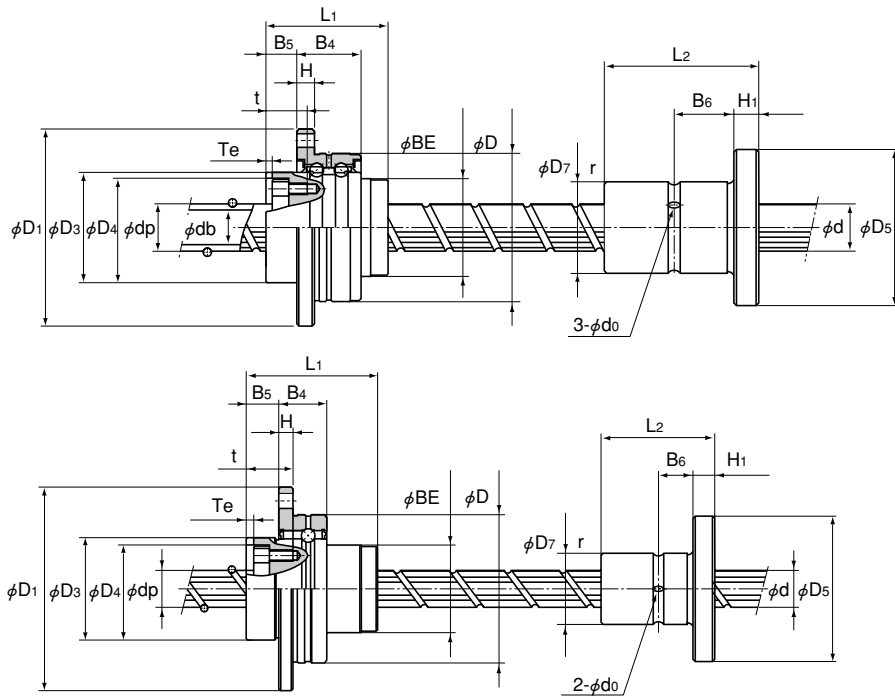

Models NS 0812A and 1015A

Unit: mm

H	B ₄	B ₅	T _e	P ₁	P ₂	S	t	d ₁	Support bearing basic load rating		Nut inertial moment kg · cm ²	Screw shaft inertial moment/mm J kg · cm ² /mm	Nut mass kg	Shaft mass kg/m
									Ca kN	C _{0a} kN				
3	10.5	7	1.5	38	14.5	M2.6	10	3.4	0.8	0.5	0.03	3.16×10 ⁻⁵	0.08	0.35
3	10.5	8	1.5	42	18	M3	11.5	3.4	0.9	0.7	0.08	7.71×10 ⁻⁵	0.15	0.52
6	21	10	2	56	25	M4	13.5	4.5	8.7	10.5	0.35	3.92×10 ⁻⁴	0.31	0.8
6	21	11	2.5	64	31	M5	16.5	4.5	9.7	13.4	0.85	9.37×10 ⁻⁴	0.54	1.21
7	25	13	3	75	38	M6	20	5.5	12.7	18.2	2.12	2.2×10 ⁻³	0.88	1.79
8	25	14	3	89	48	M6	21	6.6	13.6	22.3	5.42	5.92×10 ⁻³	1.39	2.96
10	33	16.5	3	113	61	M8	24.5	9	21.5	36.8	17.2	1.43×10 ⁻²	3.16	4.51

Unit: mm

Overall length L ₂	H ₁	B ₆	r	Greasing hole d ₀	P ₃	Mounting hole			Nut mass kg
						d _{s1}	d ₂	h	
25	5	7.5	0.5	1.5	24	3.4	6.5	3.3	0.04
33	6	10.5	0.5	1.5	32	4.5	8	4.4	0.09
50 ^{+0.2}	7	18	0.5	2	40	4.5	8	4.4	0.23
63 ^{+0.2}	9	22.5	0.5	2	45	5.5	9.5	5.4	0.33
71 ^{+0.3}	9	26.5	0.5	3	52	5.5	9.5	5.4	0.45
80 ^{+0.3}	10	30	0.5	3	62	6.6	11	6.5	0.58
100 ^{+0.3}	14	36	0.5	4	82	9	14	8.6	1.46

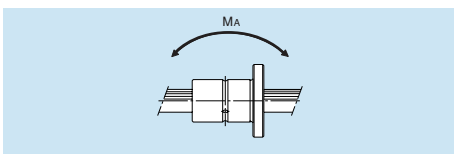

Model NS

Dimensional Table for Model NS Heavy-load Type: Linear Motion

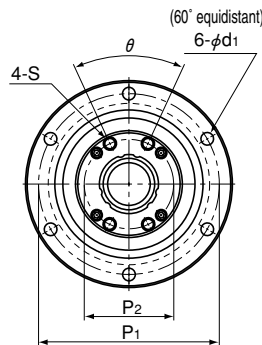

Ball screw unit

Model No.	Screw shaft outer diameter d	Screw shaft inner diameter dp	Lead Ph	Ball screw dimensions									
				Basic load rating		Ball center-to-center diameter dp	Thread minor diameter dc	Outer diameter D	Flange diameter D ₁	Overall length L ₁	D ₃ h7	D ₄ H7	
				Ca kN	C _{0a} kN								
NS 1616	16	11	16	3.9	7.2	16.65	13.7	52 ⁰ _{-0.007}	68	43.5	40	32	
NS 2020	20	14	20	6.1	12.3	20.75	17.5	62 ⁰ _{-0.007}	78	54	50	39	
NS 2525	25	18	25	9.1	19.3	26	22	72 ⁰ _{-0.007}	92	65	58	47	
NS 3232	32	23	32	13	29.8	33.25	28.3	80 ⁰ _{-0.007}	105	80	66	58	
NS 4040	40	29	40	21.4	49.7	41.75	35.2	110 ⁰ _{-0.008}	140	98	90	73	
NS 5050	50	36	50	31.8	77.6	52.2	44.1	120 ⁰ _{-0.008}	156	126	100	90	

Ball spline

Model No.	Ball spline dimensions					
	Basic load rating		Static permissible moment M _A N-m	Basic torque rating		Outer diameter D ₇
	C kN	C ₀ kN		C _T N-m	C _{0T} N-m	
NS 1616	7.1	12.6	67.6	31.4	34.3	31 ⁰ _{-0.013}
NS 2020	10.2	17.8	118	56.9	55.9	35 ⁰ _{-0.016}
NS 2525	15.2	25.8	210	105	103	42 ⁰ _{-0.016}
NS 3232	20.5	34	290	180	157	49 ⁰ _{-0.016}
NS 4040	37.8	60.5	687	419	377	64 ⁰ _{-0.019}
NS 5050	60.9	94.5	1340	842	769	80 ⁰ _{-0.019}

Note For the db dimension, solid shaft and K hollow shaft (thick) are available. For details, see the "Ball Spline" page of the General Catalog.

Example of model number coding

NS2525 +600L

Model number Overall shaft length (in mm)

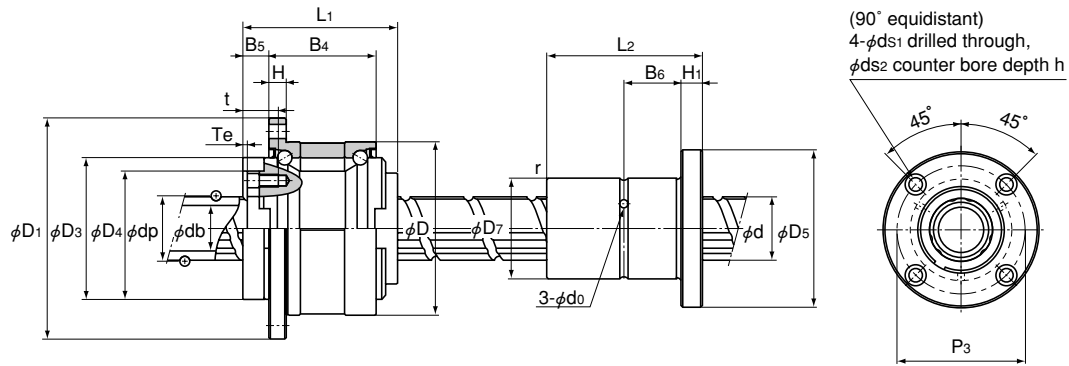

Unit: mm

	H	B ₄	B ₅	T _e	P ₁	P ₂	S	t	d _i	θ°	Support bearing basic load rating		Nut inertial moment kg · cm ²	Screw shaft inertial moment/mm J kg · cm ² /mm	Nut mass kg	Shaft mass kg/m
											Ca kN	C _{0a} kN				
	5	27.5	9	2	60	25	M4	12	4.5	40	19.4	19.2	0.48	3.92×10 ⁻⁴	0.38	0.8
	6	34	11	2	70	31	M5	16	4.5	40	26.8	29.3	1.44	9.37×10 ⁻⁴	0.68	1.21
	8	43	12.5	3	81	38	M6	19	5.5	40	28.2	33.3	3.23	2.2×10 ⁻³	1.1	1.79
	9	55	14	3	91	48	M6	19	6.6	40	30	39	6.74	5.92×10 ⁻³	1.74	2.96
	11	68	16.5	3	123	61	M8	22	9	50	59.3	74.1	27.9	1.43×10 ⁻²	3.95	4.51
	12	80	25	4	136	75	M10	28	11	50	62.2	83	58.2	3.52×10 ⁻²	6.22	7.16

Unit: mm

	Flange diameter D ₅	Overall length L ₂	H ₁	B ₅	r	Greasing hole d ₀	P ₃	Mounting hole			Nut mass kg
								d _{s1}	d ₂	h	
	51	50 _{-0.2}	7	18	0.5	2	40	4.5	8	4.4	0.23
	58	63 _{-0.2}	9	22.5	0.5	2	45	5.5	9.5	5.4	0.33
	65	71 _{-0.3}	9	26.5	0.5	3	52	5.5	9.5	5.4	0.45
	77	80 _{-0.3}	10	30	0.5	3	62	6.6	11	6.5	0.58
	100	100 _{-0.3}	14	36	0.5	4	82	9	14	8.6	1.46
	124	125 _{-0.3}	16	46.5	1	4	102	11	17.5	11	2.76

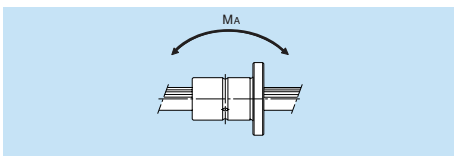

THK Precision Ball Screw/Spline Models BNS/NS

⚠ Precautions on Use

● Precautions on Handling

- Disassembling components may cause dust to enter the system or degrade the mounting accuracy of the components. Do not disassemble the components.
- Tilting the shaft and the ball screw nut (or spline nut) may cause them to fall by their own weight.
- Dropping or hitting the Precision Ball Screw/Spline may damage or fracture the ball circulation component, which may cause functional loss. Giving an impact to the product could also cause damage to its function even if the product looks intact.

● Lubrication

- Thoroughly remove anti-corrosion oil and feed a lubricant before using the product.
- Do not mix lubricants of different physical properties.
- In locations exposed to constant vibrations or in special environments, such as clean rooms, vacuum and low/high temperature, normal lubricants may not be used. Contact THK for details.
- When planning to use a special lubricant, contact THK before using it.
- Lubrication interval varies according to the service conditions. Contact THK for details.
- When lubricating the Precision Ball Screw/Spline, attach a greasing plate to the housing in advance (see the figure on the right).

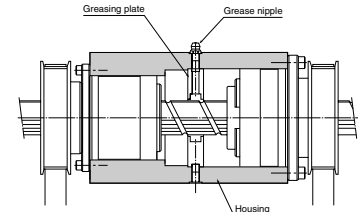

Lubrication Method

● Precautions on Use

- Do not remove the ball screw nut (or spline nut) from the shaft. Doing so may cause the balls to fall off.
- Entry of foreign material to the ball screw nut (or spline nut) may cause damage to the ball circulation component or functional loss. Prevent foreign material, such as dust or cutting chips, from entering the system.
- If foreign material adheres to the product, replenish the lubricant after cleaning the product. For the type of the detergent, contact THK.
- When planning to use the product in an environment where the coolant penetrates the ball screw nut (or spline nut), it may cause trouble to product functions depending on the type of the coolant. Contact THK for details.
- Do not use the product at temperature of 80°C or higher. When desiring to use the system at temperature of 80°C or higher, contact THK in advance.
- If using the product with vertical mount, the ball screw nut (or spline nut) may fall by its own weight. Attach a mechanism to prevent it from falling.
- Using the product at speed exceeding the permissible rotation speed may cause breakage of a component or accident. Be sure to use the product within the specification range designated by THK.
- Forcibly driving in a component may cause an indentation on the raceway. Use care when mounting components.
- If an offset or skewing occurs with the ball screw shaft support and the ball screw nut (or spline nut), it may substantially shorten the service life. Pay much attention to components to be mounted and to the mounting accuracy.
- When using the product in locations exposed to constant vibrations or in special environments such as clean rooms, vacuum and low/high temperature, contact THK in advance.
- Letting the ball screw nut (or spline nut) overshoot will cause balls to fall off or the ball circulation component to be damaged. Be sure not to let it overshoot.

● Storage

- When storing the Precision Ball Screw/Spline, enclose it in a package designated by THK and store it in a horizontal orientation while avoiding high temperature, low temperature and high humidity.

● “LM Guide,” “Caged Ball” and “,” are registered trademarks of THK CO., LTD.

- The photo may differ slightly in appearance from the actual product.
 - The appearance and specifications of the product are subject to change without notice. Contact THK before placing an order.
 - Although great care has been taken in the production of this catalog, THK will not take any responsibility for damage resulting from typographical errors or omissions.
 - For the export of our products or technologies and for the sale for exports, THK in principle complies with the foreign exchange law and the Foreign Exchange and Foreign Trade Control Law as well as other relevant laws.
- For export of THK products as single items, contact THK in advance.

All rights reserved

THK CO., LTD.

HEAD OFFICE 3-11-6, NISHI-GOTANDA, SHINAGAWA-KU, TOKYO 141-8503 JAPAN
INTERNATIONAL SALES DEPARTMENT PHONE:+81-3-5434-0351 FAX:+81-3-5434-0353

Global site : <http://www.thk.com/>

NORTH AMERICA

THK America, Inc.

● HEADQUARTERS

Phone:+1-847-310-1111 Fax:+1-847-310-1271

● CHICAGO OFFICE

Phone:+1-847-310-1111 Fax:+1-847-310-1182

● NEW YORK OFFICE

Phone:+1-845-369-4035 Fax:+1-845-369-4909

● ATLANTA OFFICE

Phone:+1-770-840-7990 Fax:+1-770-840-7897

● LOS ANGELES OFFICE

Phone:+1-949-955-3145 Fax:+1-949-955-3149

● SAN FRANCISCO OFFICE

Phone:+1-925-455-8948 Fax:+1-925-455-8965

● BOSTON OFFICE

Phone:+1-781-575-1151 Fax:+1-781-575-9295

● DETROIT OFFICE

Phone:+1-248-858-9330 Fax:+1-248-858-9455

● TORONTO OFFICE

Phone:+1-905-820-7800 Fax:+1-905-820-7811

SOUTH AMERICA

THK Brasil LTDA

Phone:+55-11-3767-0100 Fax:+55-11-3767-0101

EUROPE

THK GmbH

● EUROPEAN HEADQUARTERS

Phone:+49-2102-7425-0 Fax:+49-2102-7425-217

● DÜSSELDORF OFFICE

Phone:+49-2102-7425-0 Fax:+49-2102-7425-299

● STUTTGART OFFICE

Phone:+49-7150-9199-0 Fax:+49-7150-9199-888

● MÜNCHEN OFFICE

Phone:+49-8937-0616-0 Fax:+49-8937-0616-26

● U.K. OFFICE

Phone:+44-1908-30-3050 Fax:+44-1908-30-3070

● ITALY MILANO OFFICE

Phone:+39-039-284-2079 Fax:+39-039-284-2527

● ITALY BOLOGNA OFFICE

Phone:+39-051-641-2211 Fax:+39-051-641-2230

● SWEDEN OFFICE

Phone:+46-8-445-7630 Fax:+46-8-445-7639

● AUSTRIA OFFICE

Phone:+43-7229-51400 Fax:+43-7229-51400-79

● SPAIN OFFICE

Phone:+34-93-652-5740 Fax:+34-93-652-5746

● TURKEY OFFICE

Phone:+90-216-362-4050 Fax:+90-216-569-7150

THK France S.A.S.

Phone:+33-4-3749-1400 Fax:+33-4-3749-1401

CHINA

THK (CHINA) CO.,LTD.

● HEADQUARTERS

Phone:+86-411-8733-7111 Fax:+86-411-8733-7000

● SHANGHAI OFFICE

Phone:+86-21-6219-3000 Fax:+86-21-6219-9890

● BEIJING OFFICE

Phone:+86-10-6590-3259 Fax:+86-10-6590-3557

● CHENGDU OFFICE

Phone:+86-28-8526-8025 Fax:+86-28-8525-6357

● GUANGZHOU OFFICE

Phone:+86-20-8333-9770 Fax:+86-20-8333-9726

THK (SHANGHAI) CO.,LTD.

Phone:+86-21-6275-5280 Fax:+86-21-6219-9890

TAIWAN

THK TAIWAN CO.,LTD.

● TAIPEI HEAD OFFICE

Phone:+886-2-2888-3818 Fax:+886-2-2888-3819

● TAICHUNG OFFICE

Phone:+886-4-2359-1505 Fax:+886-4-2359-1506

● TAINAN OFFICE

Phone:+886-6-289-7668 Fax:+886-6-289-7669

KOREA

SEOUL REPRESENTATIVE OFFICE

Phone:+82-2-3468-4351 Fax:+82-2-3468-4353

SINGAPORE

THK LM SYSTEM Pte. Ltd.

Phone:+65-6884-5500 Fax:+65-6884-5550

INDIA

BANGALORE REPRESENTATIVE OFFICE

Phone:+91-80-2330-1524 Fax:+91-80-2314-8226

