



Change Nut

THK General Catalog

A Product Descriptions

Features	A17-2
Features of the Change Nut.....	A17-2
• Structure and Features.....	A17-2
• Features of the Special Rolled Shafts..	A17-3
• High Strength Zinc Alloy.....	A17-3
Point of Selection	A17-5
Selecting a Change Nut.....	A17-5
Efficiency, Thrust and Torque.....	A17-8
Accuracy Standards.....	A17-8
Dimensional Drawing, Dimensional Table	
Models DCMA and DCMB.....	A17-10
Point of Design	A17-12
Fit.....	A17-12
Installation.....	A17-12
Lubrication.....	A17-13
Model No.	A17-14
• Model Number Coding.....	A17-14
Precautions on Use	A17-15

B Support Book (Separate)

Features	B17-2
Features of the Change Nut.....	B17-2
• Structure and Features.....	B17-2
• Features of the Special Rolled Shafts..	B17-3
• High Strength Zinc Alloy.....	B17-3
Point of Selection	B17-5
Selecting a Change Nut.....	B17-5
• Example of selection calculation.....	B17-8
Efficiency, Thrust and Torque.....	B17-9
• Example of thrust force calculation.....	B17-9
• Example of torque calculation.....	B17-9
Mounting Procedure and Maintenance..	B17-10
Installation.....	B17-10
Lubrication.....	B17-11
Model No.	B17-12
• Model Number Coding.....	B17-12
Precautions on Use	B17-13

Features of the Change Nut

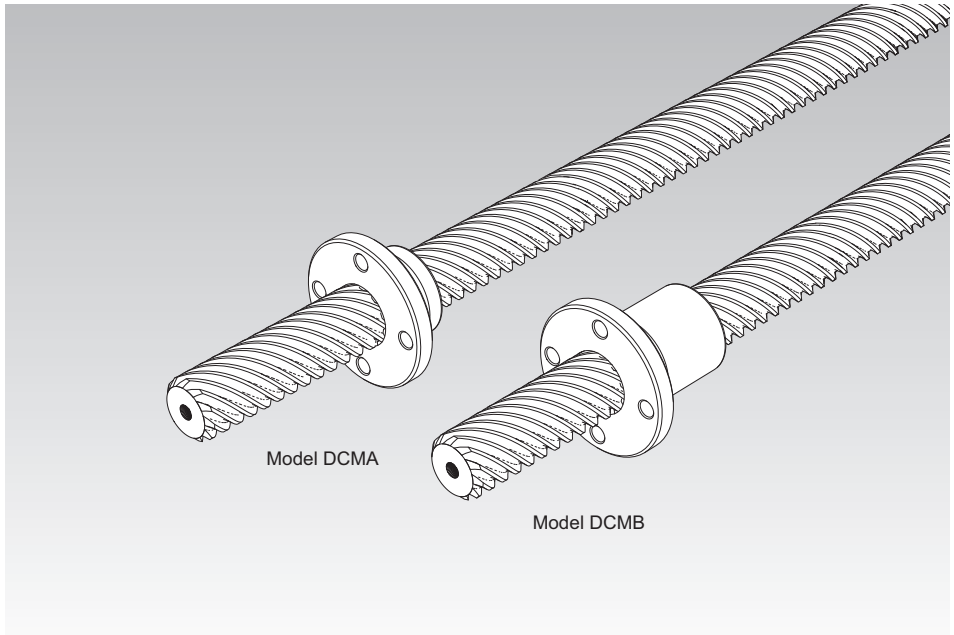

Model DCMA

Model DCMB

Structure and Features

The Change Nut models DCMA and DCMB have a lead angle of 45° , which is difficult to achieve through machining. Each model is capable of converting a straight motion to a rotary motion, or a vice versa, at high efficiency. Because of the large leads, they are optimal for providing a fast feed mechanism at a low-speed rotation. The multi-thread screw shafts to be combined with these change nuts are formed through cold gear rolling. The surface of the teeth is hardened to over 250 HV and mirror-finished. As a result, the shafts are highly wear resistant and achieve significantly smooth motion when used in combination with these change nuts. Models DCMA40, DCMB40 or higher are designed for use in combination with the cut screw shafts.

The Miniature Change Nuts are made of an oil-impregnated plastic, and have a wear resistance and excel in lubrication especially in an oil-less operation. In addition, since the high level of their performances can be maintained for a long period, they allow long-term maintenance-free operation.

Features of the Special Rolled Shafts

Dedicated rolled shafts with the standardized lengths are available for the Change Nut.

[Increased Wear Resistance]

The shaft teeth are formed by cold gear rolling, and the tooth surface is hardened to over 250 HV and mirror-finished. As a result, the shafts are highly wear resistant and achieve significantly smooth motion when used in combination with the nuts.

[Improved Mechanical Properties]

Inside the teeth of the rolled shaft, a fiber flow occurs along the contour of the tooth surface of the shaft, making the structure around the teeth roots dense. As a result, the fatigue strength is increased.

[Additional Machining of the Shaft End Support]

Since each shaft is rolled, additional machining of the support bearing of the shaft end can easily be performed by lathing or milling.

High Strength Zinc Alloy

The high strength zinc alloy used in the change nuts is a material that is highly resistant to seizure and the wear and has a high load carrying capacity. Information on mechanical properties, physical properties, and wear resistance is presented below.

* The figures shown are target values—these figures are not guaranteed.

[Mechanical Properties]

Table1

Item	Description
Tensile strength	275 to 314 N/mm ²
Tensile yield strength (0.2%)	216 to 245 N/mm ²
Compressive strength	539 to 686 N/mm ²
Compressive yield strength (0.2%)	294 to 343 N/mm ²
Fatigue strength	132 N/mm ² × 10 ⁷ (Schenk bending test)
Charpy impact	0.098 to 0.49 N-m/mm ²
Elongation	1 to 5 %
Hardness	120 to 145 HV

[Physical Properties]

Table2

Item	Description
Specific gravity	6.8
Specific heat	460 J/(kg•K)
Melting point	390 °C
Thermal expansion coefficient	24×10^{-6}

[Wear Resistance]

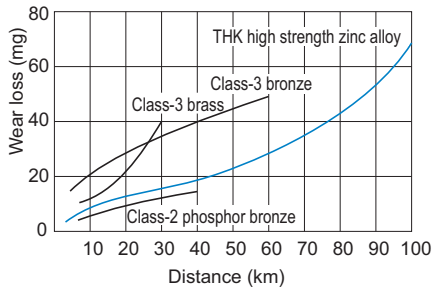

Fig.1 Wear Resistance of the High Strength Zinc Alloy

Table3 [Test conditions: Amsler wear-tester]

Item	Description
Test piece rotational speed	185 min ⁻¹
Load	392 N
Lubricant	Dynamo oil

Selecting a Change Nut

[Dynamic Permissible Torque T and Dynamic Permissible Thrust F]

The dynamic permissible torque (T) and the dynamic permissible thrust (F) are the torque and the thrust at which the contact surface pressure on the tooth surface of the bearing is 9.8 N/mm². These values are used as a measuring stick for the strength of the change nut.

[pV Value]

With a sliding bearing, a pV value, which is the product of the contact surface pressure (p) and the sliding speed (V), is used as a measuring stick to judge whether the assumed model can be used. Use the corresponding pV value indicated in Fig.1 as a guide for selecting a change nut. The pV value varies also according to the lubrication conditions.

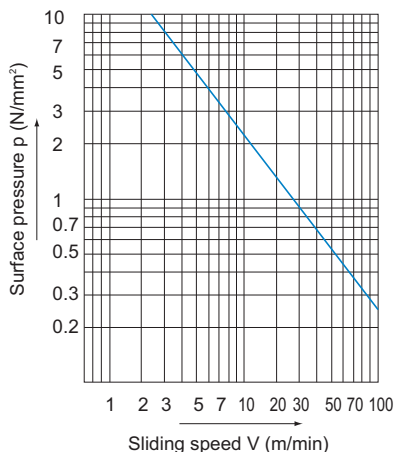

Fig.1 pV Value

Table1 Safety Factor (f_s)

Type of load	Lower limit of f_s
For a static load less frequently used	1 to 2
For an ordinary single-directional load	2 to 3
For a load accompanied by vibrations/impact	4 or greater

● f_s : Safety Factor

To calculate a load applied to the change nut, it is necessary to accurately obtain the effect of the inertia that changes with the weight and the dynamic speed of an object. In general, with the reciprocating or the rotating machines, it is not easy to accurately obtain all the factors such as the effect of the start and stop, which are always repeated. Therefore, if the actual load cannot be obtained, it is necessary to select a bearing while taking into account the empirically obtained safety factors (f_s) shown in Table1.

● f_T : Temperature Factor

If the temperature of the change nut exceeds the normal temperature range, the seizure resistance of the nut and the strength of the material will decrease. Therefore, it is necessary to multiply the dynamic permissible torque (T) and the dynamic permissible thrust (F) by the corresponding temperature factor indicated in Fig.2.

Note) In the case of a miniature Change Nut, be sure to use it at 60°C or below.

Accordingly, when selecting a change nut, the following equations need to be met in terms of its strength.

Dynamic permissible torque(T)

$$f_s \leq \frac{f_T \cdot T}{P_T}$$

Static permissible thrust(F)

$$f_s \leq \frac{f_T \cdot F}{P_F}$$

f_s : Static safety factor

(see Table1 on **A17-5**)

f_T : Temperature factor (see Fig.2)

T : Dynamic permissible torque (N-m)

P_T : Applied torque (N-m)

F : Dynamic permissible thrust (N)

P_F : Axial load (N)

● Hardness of the Surface and Wear Resistance

The hardness of the shaft significantly affects the wear resistance of the change nut. If the hardness is equal to or less than 250 HV, the abrasion loss increases as indicated in Fig.3. The roughness of the surface should preferably be Ra0.80 or less.

A special rolled shaft achieves surface hardness of 250 HV or greater, through hardening as a result of rolling, and surface roughness of Ra0.20 or less. Thus, the dedicated rolled shaft is highly wear resistant.

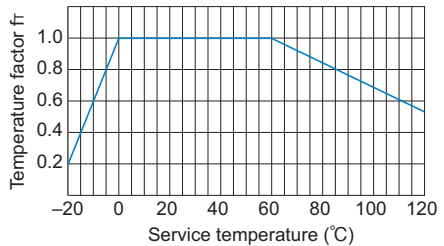

Fig.2 Temperature Factor

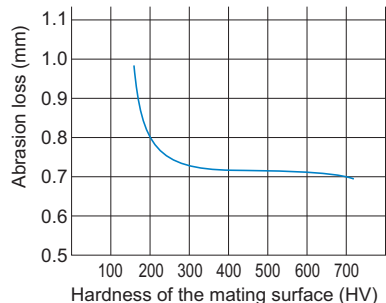

Fig.3 Hardness of the Surface and Wear Resistance

[Calculating the Contact Surface Pressure p]

The value of “p” is obtained as followed.

- If an axial load is applied:

$$p = \frac{P_F}{F} \times 9.8$$

p : Contact surface pressure on the tooth from an axial load (P_F N) (N/mm²)

F : Dynamic permissible thrust (N)

P_F : Axial load (N)

- If a torque is applied:

$$p = \frac{P_T}{T} \times 9.8$$

p : Contact surface pressure on the tooth under a load torque (P_T N-m) (N/mm²)

T : Dynamic permissible torque (N-m)

P_T : Applied torque (N-m)

[Calculating the Sliding Speed V on the Teeth]

The value of “V” is obtained as followed.

$$V = \frac{\sqrt{2 \cdot \pi \cdot D_o \cdot n}}{10^3}$$

V : Sliding speed (m/min)

D_o : Effective diameter
(see specification table) (mm)

n : Revolutions per minute (min⁻¹)

$$n = \frac{S}{R \times 10^{-3}}$$

S : Feeding speed (m/min)

R : Lead (mm)

Efficiency, Thrust and Torque

The friction coefficient of change nuts (μ) is approximately 0.1 to 0.2 as a guideline. The efficiency (η) with the friction coefficient at 0.1 to 0.2 is Table2.

* The friction coefficient may exceed the above-mentioned value depending on the lubrication and mounting conditions, so the value shall be used as a reference.

Table2 Friction Coefficient and Efficiency

Frictional coefficient (μ)	0.1	0.15	0.2
Efficiency (η)	0.82	0.74	0.67

The thrust generated when a torque is applied is obtained from the following equation.

$$F_a = 2 \cdot \pi \cdot \eta \cdot T/R \times 10^{-3}$$

F_a	: Thrust generated	(N)
T	: Torque (input)	(N-m)
R	: Lead	(mm)

Also, the torque generated when a thrust is applied is obtained from the following equation.

$$T = \eta \cdot F_a \cdot R \times 10^{-3}/2\pi$$

T	: Torque generated	(N-m)
F_a	: Thrust (input)	(N)
R	: Lead	(mm)

Accuracy Standards

Table3 Accuracy of the Screw Shaft of Models DCMA and DCMB

Unit: mm

Shaft symbol	Rolled shaft
Accuracy	T^{Note}
Single pitch error (max)	± 0.025
Accumulated pitch error (max)	$\pm 0.2/300$

Note) Symbol T indicates the machining method for the screw shaft.

Point of Selection

Efficiency, Thrust and Torque

Change Nut

Models DCMA and DCMB

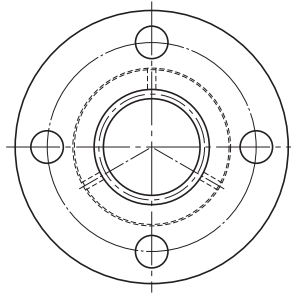

Change Nut Model No. ^(note 1)	Outer dimensions			Change nut dimensions							Screw shaft Model No. ^(note 1)
	Outer diameter		Length L	Flange diameter D ₁	H	B	PCD	r	F	d	
	D	Tolerance h9									
DCMB 8T ^(note 2)	15	0	16	28	4	3.4	21	0.8	—	—	CT 8T
DCMB 12T ^(note 2)	20	-0.1	25	36	5	4.5	27	1	—	—	CT 12T
DCMA 15T	22	0	15	44	6	5.4	31	1.5	4.5	1.5	CT 15T
DCMB 15T			30								
DCMA 17T	28	-0.052	15	51	7	6.6	38	1.5	4.5	1.5	CT 17T
DCMB 17T			35								
DCMA 20T	32	0	20	56	7	6.6	42	1.5	6.5	2	CT 20T
DCMB 20T			40								
DCMA 25T	36	-0.062	25	61	8	6.6	47	2	8.5	2	CT 25T
DCMB 25T			50								
DCMA 30T	44	0	28	76	10	9	58	2	9	2	CT 30T
DCMB 30T			56								
DCMA 35T	52	0	30	84	10	9	66	2.5	10	3	CT 35T
DCMB 35T			60								
★ DCMA 40	58	0	35	98	12	11	76	2.5	11.5	3	☆ CT 40
★ DCMB 40			70								
★ DCMA 45	64	-0.074	37	104	12	11	80	2.5	12.5	3	☆ CT 45
★ DCMB 45			75								
★ DCMA 50	68	0	40	109	12	11	85	2.5	14	3	☆ CT 50
★ DCMB 50			80								

Note1) The T symbol designated to the model numbers for change nuts (excluding models DCMB8T and DCMB12T) and screw shafts indicate rolled products. Refer to model number coding on **A17-11** when selecting nut and shaft separately.

Note2) Miniature Change Nut models DCMB8T and DCMB12T use oil-impregnated plastics.(outer diameter tolerance: special).

Note3) The permissible dynamic torque (T) or permissible dynamic thrust (F) is the value at which the contact surface pressure on the screw tooth surface is 9.8 N/mm².The maximum axial load (both when stopped and during operation) is set to the dynamic permissible thrust or below, and it must be selected while taking into consideration the safety factor of Table1 on **A17-5**.

Note4) The static permissible load (P) of the flange indicates the strength of the flange against the load as shown in the figure on the right.

☆: Indicates products for which the screw shaft is made to order.

★: Since the screw shaft and the change nut are build-to-order parts, they are sold only in a set consisting of the shaft and the nut.

Model number coding

Combination of change nut and screw shaft

2 DCMA20 +1500L T

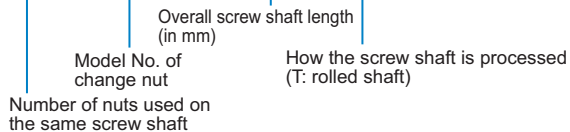

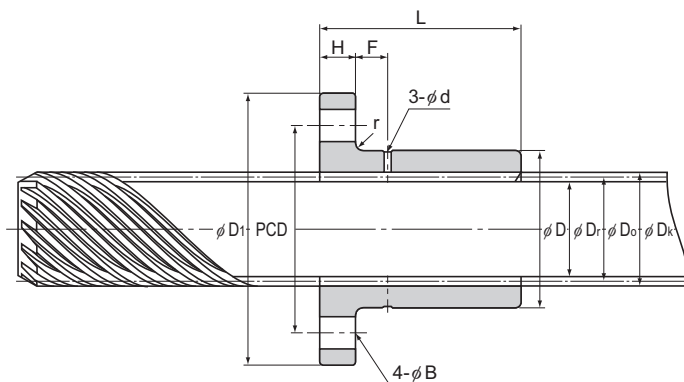

Unit: mm

Multi-thread screw shaft details							Standard shaft length	Maximum shaft length	Dynamic permissible torque $T^{(note\ 3)}$	Dynamic permissible thrust $F^{(note\ 3)}$	Static permissible load of the flange $P^{(note\ 4)}$	Mass	
Outer diameter D_k	Effective diameter D_o	Thread minor diameter D_1	Lead R	Lead angle α°	Threaded grooves Z	Change nut g						Screw shaft kg/m	
9	7.6	6.2	24	(45)	6	500	1000	3.24	863	1800	5	0.36	
13.3	11.5	9.7	36	(45)	7	500,1000	1500	12.7	1370	2800	10	0.82	
15.8	13.7	11.6	44.4	(45)	8	500,1000	1500	16.7	2300	13800	60	1.2	
								32.4	4610		85		
17.8	15.7	13.6	50	(45)	9	500,1000	1500	20.6	2600	28100	95	1.5	
								48	6080		140		
21.2	18.7	16.2	60	(45)	9	500,1000,1500	3000	40.2	4170	34600	135	2.6	
								79.4	8330		210		
25.6	23.1	20.6	73.3	(45)	11	500,1000,1500	3000	74.5	6370	38500	175	3.3	
								148	12700		280		
31.9	29.4	26.9	93.3	(45)	14	500,1000,2000	4000	130	8090	55400	290	5.3	
								269	16200		465		
34.1	31.1	28.1	97.7	(45)	11	500,1000,2000	4000	144	9260	84500	425	5.8	
								287	18500		670		
44	38.18	33.3	119.9	(45)	12	500,1000,2000	—	381	20000	85200	715	9	
								763	40000		1065		
47	41.37	36.4	129.9	(45)	13	1000,2000,3000	—	474	22900	115000	820	10.6	
								960	46600		1270		
52	47.73	42.9	149.9	(45)	15	1000,2000,3000	—	681	28500	108000	925	14	
								1360	57100		1375		

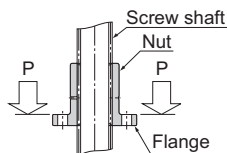

Model number coding

- Change Nut only

DCMA20T

Model No. of change nut

- Multi-thread screw shaft

CT20 T +1500L

How the screw shaft is processed (T: rolled shaft) Overall screw shaft length (in mm)

Model number of screw shaft

Fit

For the fitting between the change nut outer diameter and the housing, we recommend a loose fit.
Housing inner-diameter tolerance: G7

Installation

[About Chamfer of the Housing's Mouth]

To increase the strength of the root of the flange of the change nut, the corner is machined to have an R shape. Therefore, it is necessary to chamfer the inner edge of the housing's mouth.

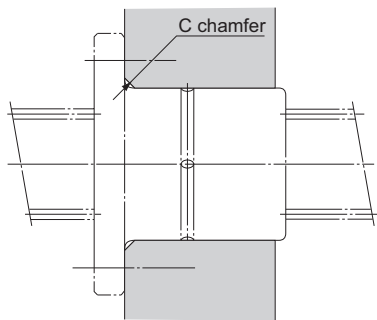

Fig.1

Table1 Chamfer of the Housing's Mouth

Unit: mm

Model No.	Chamfer of the mouth C (Min.)
DCMA DCMB	
8	1.2
12	1.5
15	2
17	
20	
25	2.5
30	
35	3
40	
45	
50	

Lubrication

Since the Change Nut is delivered without a lubricant/grease, it is necessary to replenish an appropriate amount of lubricant/grease after installing the bearing.

Select a lubrication method according to the service conditions.

[Oil Lubrication]

Oil is recommended for lubricating the change nut. Specifically, oil bath lubrication and drip lubrication are both effective oil lubrication methods. Oil bath lubrication is suited for use under difficult conditions, such as the need for high speed or heavy loads, or when heat is transferred from outside. It is an ideal method because the change nut is also cooled. Drip lubrication is suited for use at medium or low speed, and with medium or light loads. Select the lubricant based on the usage conditions, as shown in Table2.

Table2 Selection of a Lubricant

Conditions	Types of Lubricants
Low speed/High load/ High temperature	High-viscosity sliding surface oil or turbine oil
High speed/Light load/ Low temperature	Low-viscosity sliding surface oil or turbine oil

[Grease Lubrication]

In a low-speed feed, which occurs less frequently, the user can lubricate the slide system by manually applying the grease to the shaft on a regular basis or using the greasing hole on the change nut. We recommend using lithium-soap group grease No. 2.

[Initial Lubrication of the Miniature Change Nut]

Since the miniature change nut is made of oil-retaining plastic, it can be used without lubrication. Use oil or grease for the initial lubrication. Note, however, that lubricants with large amounts of added extreme pressure agents are not suitable for this application.

Model Number Coding

Model number configurations differ depending on the model features. Refer to the corresponding sample model number configuration.

[Change Nut]

● Models DCMA, DCMB and CT

- Change Nut only

DCMA20T

Model No. of
change nut

- Screw shaft

CT20 T +1500L

How the screw shaft
is processed
(T: rolled shaft) Overall screw shaft length
(in mm)

Model number of screw shaft

- Combination of
lead screw nut and screw shaft

2 DCMA20 +1500L T

Number of nuts used on
the same screw shaft

Model No. of
change nut

Overall screw
shaft length
(in mm)

How the screw shaft is processed
(T: rolled shaft)

[Handling]

- (1) Make sure the Change Nut is not dropped or subjected to any sudden impact, as this could cause injury and damage the product. Even if there is no outward indication of damage, a sudden impact could prevent the unit from functioning properly.
- (2) When handling the product, wear protective gloves, safety shoes, etc., as necessary to ensure safety.

[Precautions on Use]

- (1) Prevent foreign material, such as cutting chips or coolant, from entering the product. Failure to do so may cause damage.
- (2) If the product is used in an environment where cutting chips, coolant, corrosive solvents, water, etc., may enter the product, use bellows, covers, etc., to prevent them from entering the product.
- (3) If foreign material such as cutting chips adheres to the product, replenish the lubricant after cleaning the product.
- (4) Do not forcibly drive a pin, key, or other positioning device into this product; this could create indentations on the sliding surface and impair the product's function.
- (5) Skewing or misalignment of the Change Nut and the element that supports the screw shaft can drastically reduce service life. Inspect the components carefully and make sure they are mounted correctly.
- (6) If the unit will be positioned vertically, install safety equipment or take other measures to prevent it from toppling over.
- (7) To avoid damaging the product, use the Change Nut in combination with an LM Guide, Ball Spline, or other guide element.
- (8) Insufficient rigidity or accuracy of mounting members causes the bearing load to concentrate on one point and the bearing performance will drop significantly. Accordingly, give sufficient consideration to the rigidity/accuracy of the housing and base and strength of the fixing bolts.

[Lubrication]

- (1) Thoroughly wipe off anti-rust oil and feed lubricant before using the product.
- (2) Do not mix different lubricants. Even lubricants containing the same type of thickening agent may, if mixed, interact in an adverse manner due to disparate additives or other ingredients.
- (3) When using the product in locations exposed to constant vibrations or in special environments such as clean rooms, vacuum and low/high temperature, use the grease appropriate for the specification/environment.
- (4) Following lubrication, perform several warm-up strokes with the unit to ensure that lubricant permeates the interior.
- (5) Lubricant viscosity can vary depending on the temperature. Please keep in mind that the Change Nut's sliding resistance may be affected by changes in viscosity.
- (6) Following lubrication, stirring-resistance within the lubricant can cause the Change Nut to exhibit increased rotational torque. Before commencing operations, make sure to run the unit through several warm-up cycles to ensure that the lubricant is adequately integrated and dispersed.
- (7) Excess grease may scatter immediately after lubrication, so wipe off scattered grease as necessary.
- (8) The properties of grease deteriorate and its lubrication performance drops over time, so grease must be checked and added properly according to the use frequency of the machine.
- (9) The greasing interval varies depending on the use condition and service environment. Set the final lubrication interval/amount based on the actual machine.

(10) If a lubricant will be used, the application must be designed in such a way that the direction in which the Change Nut is installed does not prevent lubricant from circulating.

(11) The miniature Change Nut, which is made of oil-impregnated plastic, can be used without lubrication. If initial lubrication is desired, the preferred lubricant is oil or grease. Do not use an extreme-pressure agent.

[Storage]

Change Nuts should be stored horizontally in their original packaging in an indoor location where they are not exposed to abnormally high or low temperatures or high humidity.

[Disposal]

Dispose of the product properly as industrial waste.



Change Nut

THK General Catalog

B Support Book

Features	B17-2
Features of the Change Nut	B17-2
• Structure and Features	B17-2
• Features of the Special Rolled Shafts..	B17-3
• High Strength Zinc Alloy.....	B17-3
Point of Selection	B17-5
Selecting a Change Nut.....	B17-5
• Example of selection calculation	B17-8
Efficiency, Thrust and Torque	B17-9
• Example of thrust force calculation	B17-9
• Example of torque calculation	B17-9
Mounting Procedure and Maintenance ..	B17-10
Installation	B17-10
Lubrication	B17-11
Model No.	B17-12
• Model Number Coding	B17-12
Precautions on Use	B17-13

A Product Descriptions (Separate)

Features	A17-2
Features of the Change Nut	A17-2
• Structure and Features	A17-2
• Features of the Special Rolled Shafts..	A17-3
• High Strength Zinc Alloy.....	A17-3
Point of Selection	A17-5
Selecting a Change Nut.....	A17-5
Efficiency, Thrust and Torque	A17-8
Accuracy Standards	A17-8
Dimensional Drawing, Dimensional Table	
Models DCMA and DCMB	A17-10
Point of Design	A17-12
Fit.....	A17-12
Installation	A17-12
Lubrication	A17-13
Model No.	A17-14
• Model Number Coding	A17-14
Precautions on Use	A17-15

Features of the Change Nut

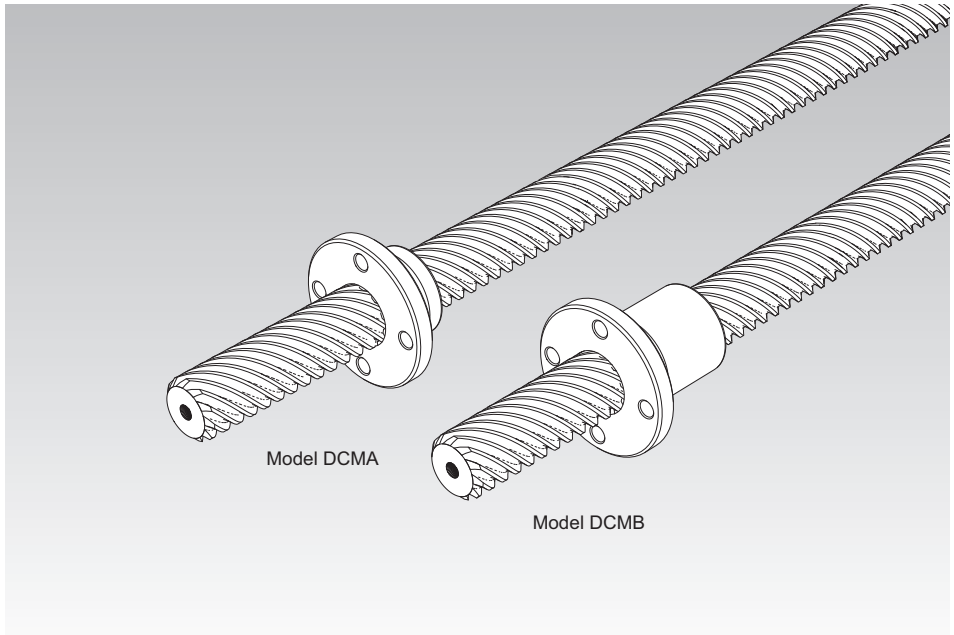

Model DCMA

Model DCMB

Structure and Features

The Change Nut models DCMA and DCMB have a lead angle of 45° , which is difficult to achieve through machining. Each model is capable of converting a straight motion to a rotary motion, or a vice versa, at high efficiency. Because of the large leads, they are optimal for providing a fast feed mechanism at a low-speed rotation. The multi-thread screw shafts to be combined with these change nuts are formed through cold gear rolling. The surface of the teeth is hardened to over 250 HV and mirror-finished. As a result, the shafts are highly wear resistant and achieve significantly smooth motion when used in combination with these change nuts. Models DCMA40, DCMB40 or higher are designed for use in combination with the cut screw shafts.

The Miniature Change Nuts are made of an oil-impregnated plastic, and have a wear resistance and excel in lubrication especially in an oil-less operation. In addition, since the high level of their performances can be maintained for a long period, they allow long-term maintenance-free operation.

Features of the Special Rolled Shafts

Dedicated rolled shafts with the standardized lengths are available for the Change Nut.

[Increased Wear Resistance]

The shaft teeth are formed by cold gear rolling, and the tooth surface is hardened to over 250 HV and mirror-finished. As a result, the shafts are highly wear resistant and achieve significantly smooth motion when used in combination with the nuts.

[Improved Mechanical Properties]

Inside the teeth of the rolled shaft, a fiber flow occurs along the contour of the tooth surface of the shaft, making the structure around the teeth roots dense. As a result, the fatigue strength is increased.

[Additional Machining of the Shaft End Support]

Since each shaft is rolled, additional machining of the support bearing of the shaft end can easily be performed by lathing or milling.

High Strength Zinc Alloy

The high strength zinc alloy used in the change nuts is a material that is highly resistant to seizure and the wear and has a high load carrying capacity. Information on mechanical properties, physical properties, and wear resistance is presented below.

* The figures shown are target values—these figures are not guaranteed.

[Mechanical Properties]

Table1

Item	Description
Tensile strength	275 to 314 N/mm ²
Tensile yield strength (0.2%)	216 to 245 N/mm ²
Compressive strength	539 to 686 N/mm ²
Compressive yield strength (0.2%)	294 to 343 N/mm ²
Fatigue strength	132 N/mm ² × 10 ⁷ (Schenk bending test)
Charpy impact	0.098 to 0.49 N-m/mm ²
Elongation	1 to 5 %
Hardness	120 to 145 HV

[Physical Properties]

Table2

Item	Description
Specific gravity	6.8
Specific heat	460 J/(kg•K)
Melting point	390 °C
Thermal expansion coefficient	24×10^{-6}

[Wear Resistance]

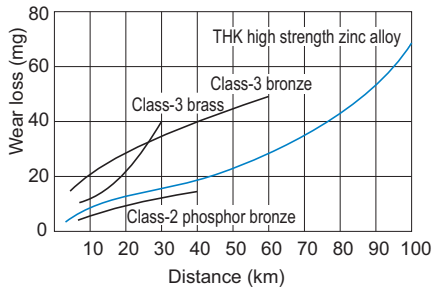

Fig.1 Wear Resistance of the High Strength Zinc Alloy

Table3 [Test conditions: Amsler wear-tester]

Item	Description
Test piece rotational speed	185 min ⁻¹
Load	392 N
Lubricant	Dynamo oil

Selecting a Change Nut

[Dynamic Permissible Torque T and Dynamic Permissible Thrust F]

The dynamic permissible torque (T) and the dynamic permissible thrust (F) are the torque and the thrust at which the contact surface pressure on the tooth surface of the bearing is 9.8 N/mm². These values are used as a measuring stick for the strength of the change nut.

[pV Value]

With a sliding bearing, a pV value, which is the product of the contact surface pressure (p) and the sliding speed (V), is used as a measuring stick to judge whether the assumed model can be used. Use the corresponding pV value indicated in Fig.1 as a guide for selecting a change nut. The pV value varies also according to the lubrication conditions.

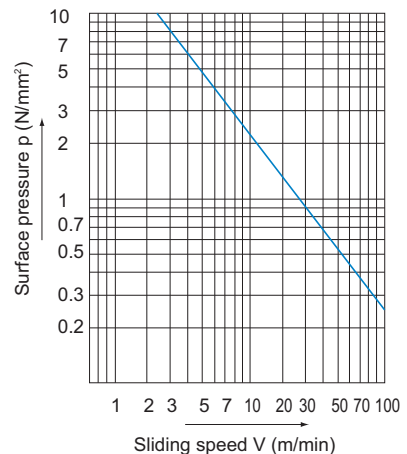

Fig.1 pV Value

Table1 Safety Factor (f_s)

Type of load	Lower limit of f_s
For a static load less frequently used	1 to 2
For an ordinary single-directional load	2 to 3
For a load accompanied by vibrations/impact	4 or greater

● f_s : Safety Factor

To calculate a load applied to the change nut, it is necessary to accurately obtain the effect of the inertia that changes with the weight and the dynamic speed of an object. In general, with the reciprocating or the rotating machines, it is not easy to accurately obtain all the factors such as the effect of the start and stop, which are always repeated. Therefore, if the actual load cannot be obtained, it is necessary to select a bearing while taking into account the empirically obtained safety factors (f_s) shown in Table1.

● f_T : Temperature Factor

If the temperature of the change nut exceeds the normal temperature range, the seizure resistance of the nut and the strength of the material will decrease. Therefore, it is necessary to multiply the dynamic permissible torque (T) and the dynamic permissible thrust (F) by the corresponding temperature factor indicated in Fig.2.

Note) In the case of a miniature Change Nut, be sure to use it at 60°C or below.

Accordingly, when selecting a change nut, the following equations need to be met in terms of its strength.

Dynamic permissible torque(T)

$$f_s \leq \frac{f_T \cdot T}{P_T}$$

Static permissible thrust(F)

$$f_s \leq \frac{f_T \cdot F}{P_F}$$

f_s : Static safety factor

(see Table1 on **B17-5**)

f_T : Temperature factor (see Fig.2)

T : Dynamic permissible torque (N-m)

P_T : Applied torque (N-m)

F : Dynamic permissible thrust (N)

P_F : Axial load (N)

● Hardness of the Surface and Wear Resistance

The hardness of the shaft significantly affects the wear resistance of the change nut. If the hardness is equal to or less than 250 HV, the abrasion loss increases as indicated in Fig.3. The roughness of the surface should preferably be Ra0.80 or less.

A special rolled shaft achieves surface hardness of 250 HV or greater, through hardening as a result of rolling, and surface roughness of Ra0.20 or less. Thus, the dedicated rolled shaft is highly wear resistant.

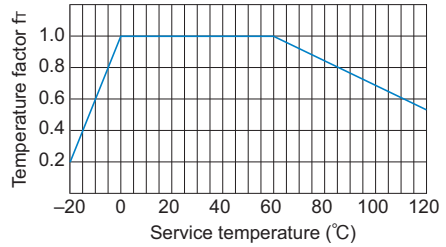

Fig.2 Temperature Factor

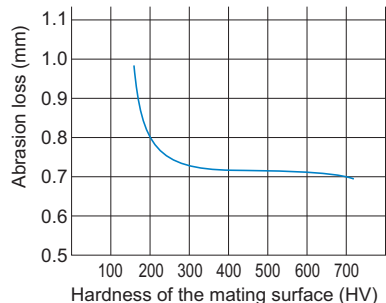

Fig.3 Hardness of the Surface and Wear Resistance

[Calculating the Contact Surface Pressure p]

The value of “p” is obtained as followed.

- If an axial load is applied:

$$p = \frac{P_F}{F} \times 9.8$$

p : Contact surface pressure on the tooth from an axial load (P_F N) (N/mm²)

F : Dynamic permissible thrust (N)

P_F : Axial load (N)

- If a torque is applied:

$$p = \frac{P_T}{T} \times 9.8$$

p : Contact surface pressure on the tooth under a load torque (P_T N-m) (N/mm²)

T : Dynamic permissible torque (N-m)

P_T : Applied torque (N-m)

[Calculating the Sliding Speed V on the Teeth]

The value of “V” is obtained as followed.

$$V = \frac{\sqrt{2 \cdot \pi \cdot D_o \cdot n}}{10^3}$$

V : Sliding speed (m/min)

D_o : Effective diameter
(see specification table) (mm)

n : Revolutions per minute (min⁻¹)

$$n = \frac{S}{R \times 10^{-3}}$$

S : Feeding speed (m/min)

R : Lead (mm)

Example of selection calculation

Assuming that Change Nut model DCMB is used, select a screw nut that travels at feed speed $S = 10$ m/min while receiving an axial load $P_F = 1,760$ N accompanied by vibrations.

Obtain the pV value.

First, tentatively select model DCMB25T (dynamic permissible thrust $F = 12,700$ N).

Obtain the contact surface pressure (p).

$$p = \frac{P_F}{F} \times 9.8 = \frac{1760}{12700} \times 9.8 \doteq 1.36 \text{ N/mm}^2$$

Obtain the sliding speed (V). The revolutions per minute (n) of the screw shaft needed to move it at feed speed $S = 10$ m/min is calculated as follows.

$$n = \frac{S}{R \times 10^{-3}} = \frac{10}{73.3 \times 10^{-3}} \doteq 136 \text{ min}^{-1}$$

$$V = \frac{\sqrt{2} \cdot \pi \cdot D_o \cdot n}{10^3} = \frac{\sqrt{2} \times \pi \times 23.1 \times 136}{10^3} \doteq 14.0 \text{ m/min}$$

From the diagram of pV values (see Fig.1 on [B17-5](#)), it is judged that there will be no abnormal wear if the sliding speed (V) is 16m/min or below against the “ p ” value of 1.36 N/mm².

Second, obtain the safety factor (f_s) against the dynamic permissible thrust (F).

Given the conditions:

Temperature factor $f_T = 1$, and

Applied load $P_F = 1,760$ N, the safety factor is calculated as follows.

$$f_s \leq \frac{f_T \cdot F}{P_F} = \frac{1 \times 12700}{1760} = 7.2$$

Since the required strength will be met if “ f_s ” is at least 4 because of the type of load, it is appropriate to select model DCMB25T.

Efficiency, Thrust and Torque

The friction coefficient of change nuts (μ) is approximately 0.1 to 0.2 as a guideline. The efficiency (η) with the friction coefficient at 0.1 to 0.2 is Table2.

* The friction coefficient may exceed the above-mentioned value depending on the lubrication and mounting conditions, so the value shall be used as a reference.

Table2 Friction Coefficient and Efficiency

Frictional coefficient (μ)	0.1	0.15	0.2
Efficiency (η)	0.82	0.74	0.67

The thrust generated when a torque is applied is obtained from the following equation.

$$F_a = 2 \cdot \pi \cdot \eta \cdot T / R \times 10^{-3}$$

F_a	: Thrust generated	(N)
T	: Torque (input)	(N-m)
R	: Lead	(mm)

Also, the torque generated when a thrust is applied is obtained from the following equation.

$$T = \eta \cdot F_a \cdot R \times 10^{-3} / 2\pi$$

T	: Torque generated	(N-m)
F_a	: Thrust (input)	(N)
R	: Lead	(mm)

Example of thrust force calculation

Assuming that Change Nut model DCMB20T is used and the torque T is equal to 19.6 N-m, obtain the thrust to be generated.

If " μ " is 0.2, the efficiency " η " is 0.67 (see Table2), and the generated thrust (F_a) is calculated as follows.

$$F_a = 2 \cdot \pi \cdot \eta \cdot T / (R \times 10^{-3}) = \frac{2 \times \pi \times 0.67 \times 19.6}{60 \times 10^{-3}} \doteq 1370 \text{ N}$$

Example of torque calculation

Assuming that Change Nut model DCMB20T is used and the thrust F_a is equal to 980 N, obtain the torque to be generated.

If " μ " is 0.2, the efficiency " η " is 0.67 (see Table2), and the generated torque (T) is calculated as follows.

$$T = \frac{\eta \cdot F_a \cdot R \times 10^{-3}}{2\pi} = \frac{0.67 \times 980 \times 60 \times 10^{-3}}{2\pi} = 6.27 \text{ N} \cdot \text{m}$$

Installation

[About Chamfer of the Housing's Mouth]

To increase the strength of the root of the flange of the change nut, the corner is machined to have an R shape. Therefore, it is necessary to chamfer the inner edge of the housing's mouth.

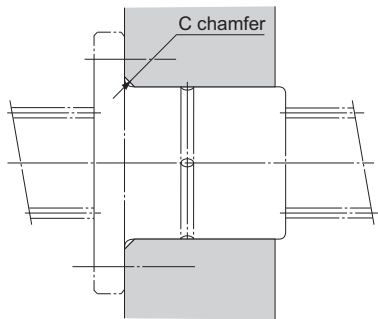

Fig.1

Table1 Chamfer of the Housing's Mouth

Unit: mm

Model No.	Chamfer of the mouth C (Min.)
DCMA DCMB	
8	1.2
12	1.5
15	2
17	
20	
25	2.5
30	
35	3
40	
45	
50	

Lubrication

Since the Change Nut is delivered without a lubricant/grease, it is necessary to replenish an appropriate amount of lubricant/grease after installing the bearing.

Select a lubrication method according to the service conditions.

[Oil Lubrication]

For the lubrication of the change nut, an oil lubrication is recommended. Specifically, an oil-bath lubrication or a drop lubrication is particularly effective. An oil-bath lubrication is the most appropriate method since it meets the harsh conditions such as a high speed, a heavy load or an external heat transmission and it cools the change nut. The drop lubrication is appropriate for the low to medium speed and a light to medium load. Select a lubricant according to the conditions as indicated in Table2.

Table2 Selection of a Lubricant

Conditions	Types of Lubricants
Low speed, high load, high temperature	High-viscosity sliding surface oil or turbine oil
High speed, light load, low temperature	Low-viscosity sliding surface oil or turbine oil

[Grease Lubrication]

In a low-speed feed, which occurs less frequently, the user can lubricate the slide system by manually applying the grease to the shaft on a regular basis or using the greasing hole on the change nut. We recommend using the lithium-soap group grease No. 2.

[Initial Lubrication of the Miniature Change Nut]

Since the Miniature Change Nut is made of oil-impregnated plastics, it can be used without the lubrication during an operation. For the initial lubrication, use some oil or grease. Note that lubricants containing large amount of extreme pressure agent are not suitable.

Model Number Coding

Model number configurations differ depending on the model features. Refer to the corresponding sample model number configuration.

[Change Nut]

● Models DCMA, DCMB and CT

- Change Nut only

DCMA20T

Model No. of
change nut

- Screw shaft

CT20 T +1500L

How the screw shaft
is processed
(T: rolled shaft) Overall screw shaft length
(in mm)

Model number of screw shaft

- Combination of
lead screw nut and screw shaft

2 DCMA20 +1500L T

Number of nuts used on
the same screw shaft

Model No. of
change nut

Overall screw
shaft length
(in mm)

How the screw shaft is processed
(T: rolled shaft)

[Handling]

- (1) Make sure the Change Nut is not dropped or subjected to any sudden impact, as this could cause injury and damage the product. Even if there is no outward indication of damage, a sudden impact could prevent the unit from functioning properly.
- (2) When handling the product, wear protective gloves, safety shoes, etc., as necessary to ensure safety.

[Precautions on Use]

- (1) Prevent foreign material, such as cutting chips or coolant, from entering the product. Failure to do so may cause damage.
- (2) If the product is used in an environment where cutting chips, coolant, corrosive solvents, water, etc., may enter the product, use bellows, covers, etc., to prevent them from entering the product.
- (3) If foreign material such as cutting chips adheres to the product, replenish the lubricant after cleaning the product.
- (4) Do not forcibly drive a pin, key, or other positioning device into this product; this could create indentations on the sliding surface and impair the product's function.
- (5) Skewing or misalignment of the Change Nut and the element that supports the screw shaft can drastically reduce service life. Inspect the components carefully and make sure they are mounted correctly.
- (6) If the unit will be positioned vertically, install safety equipment or take other measures to prevent it from toppling over.
- (7) To avoid damaging the product, use the Change Nut in combination with an LM Guide, Ball Spline, or other guide element.
- (8) Insufficient rigidity or accuracy of mounting members causes the bearing load to concentrate on one point and the bearing performance will drop significantly. Accordingly, give sufficient consideration to the rigidity/accuracy of the housing and base and strength of the fixing bolts.

[Lubrication]

- (1) Thoroughly wipe off anti-rust oil and feed lubricant before using the product.
- (2) Do not mix different lubricants. Even lubricants containing the same type of thickening agent may, if mixed, interact in an adverse manner due to disparate additives or other ingredients.
- (3) When using the product in locations exposed to constant vibrations or in special environments such as clean rooms, vacuum and low/high temperature, use the grease appropriate for the specification/environment.
- (4) Following lubrication, perform several warm-up strokes with the unit to ensure that lubricant permeates the interior.
- (5) Lubricant viscosity can vary depending on the temperature. Please keep in mind that the Change Nut's sliding resistance may be affected by changes in viscosity.
- (6) Following lubrication, stirring-resistance within the lubricant can cause the Change Nut to exhibit increased rotational torque. Before commencing operations, make sure to run the unit through several warm-up cycles to ensure that the lubricant is adequately integrated and dispersed.
- (7) Excess grease may scatter immediately after lubrication, so wipe off scattered grease as necessary.
- (8) The properties of grease deteriorate and its lubrication performance drops over time, so grease must be checked and added properly according to the use frequency of the machine.
- (9) The greasing interval varies depending on the use condition and service environment. Set the final lubrication interval/amount based on the actual machine.

(10) If a lubricant will be used, the application must be designed in such a way that the direction in which the Change Nut is installed does not prevent lubricant from circulating.

(11) The miniature Change Nut, which is made of oil-impregnated plastic, can be used without lubrication. If initial lubrication is desired, the preferred lubricant is oil or grease. Do not use an extreme-pressure agent.

[Storage]

Change Nuts should be stored horizontally in their original packaging in an indoor location where they are not exposed to abnormally high or low temperatures or high humidity.

[Disposal]

Dispose of the product properly as industrial waste.